

21st Asia Experts Meeting on Noise (ECE R41 and R51) and Safety Glass (ECE R43)

Date: 1-2 October 2009

Place: LTO Bulwagan Edu, East Avenue, Quezon City, Philippines

Day 1	
Time	Agenda
08:30- 09:00	Registration of Participants
09:00- 09:15	Invocation and Philippine National Anthem
09:15- 09:30	Welcome Remarks - Gen. Arturo C. Lomibao, Assistant Secretary, LTO
09:30- 09:45	Message – Hon. Anneli R. Lontoc, Undersecretary for Road Transport, DOTC
09:45- 10:15	Coffee Break
10:15-11:15	Noise Regulation: General information Mr. Yoshihiro Shirahashi, Noise Subcommittee, JASIC
11:15-12:15	R41 (Noise: Motor Cycles): Technical Requirements. Mr. Shigeki Yonezawa, Noise Subcommittee, JASIC
12:15- 13:15	Lunch
13:15- 14:45	R51 (Noise: Motor Vehicles with 4 wheels and more): Technical Requirements Mr. Yoshihiro Shirahashi, Noise Subcommittee, JASIC
14:45- 15:15	Coffee Break
15:15- 15:45	R41 & R51: Testing Method & Equipments (video) Mr. Shigeki Yonezawa, Mr. Yoshihiro Shirahashi, Noise Subcommittee, JASIC
15:45- 16:30	Q & A
Day 2	
08:30- 09:00	Registration
09:00- 09:45	R43: General Information Mr. Masaru Morikawa, General Safety Subcommittee, JASIC
09:45 - 10:15	Coffee Break
10:15- 10:45	R43: Safety Glazing Mr. Masaru Morikawa, General Safety Subcommittee, JASIC
10:45-11:45	R43: Technical requirement and Testing Method for Glass Mr. Masaru Morikawa, General Safety Subcommittee, JASIC
11:45-12:15	Q & A
12:15-12:30	Closing Remarks – Atty. Jimmy G. Pesigan, Executive Director, LTO
	Lunch

The background of the slide is a photograph of a park during autumn. The trees have yellow and orange leaves, and the ground is covered with fallen leaves. A black lamppost is visible in the foreground on the left.

**ECE R41, R51
NOISE on motorcycles and passenger cars**

Y. Shirahashi
S. Yonezawa
JASIC Noise-sub committee

General information



ECE R41, R51 NOISE on motorcycles and passenger cars

Yoshihiro Shirahashi

JASIC Noise Subcommittee

Contents



1. WP29 and GRB

2. Common Information on R41/R51

- 1) Vehicle categories
- 2) Histories
- 3) Application
- 4) Approval
- 5) Marking
- 6) COP
- 7) Penalties



The United Nation's Organization



- ECE noise regulations are taken care by the group of UN/WP29/GRB.



UN

ECE



Inland TRANS Committee

WP29

World Forum for Harmonization of Vehicle Regulations

GRB

GRE

GRPE

GRRF

GRSG

GRSP

Noise

Light

Prolusion &
Energy

Brake &
Running Gear

General
Safety

Passive
Safety

GRB : Working Party on Noise



Object ECE regulations of GRB

ECE R 9 Noise (Three-Wheeled Vehicles)

ECE R 28 Audible Warning Devices

ECE R 41 Noise (Motor Cycle)

ECE R 51 Noise (Motor Vehicles having at least four wheels)

ECE R 59 Replacement Silencing System

ECE R 63 Noise (Moped)

ECE R 92 Replacement Silencing System (Motor Cycle)

ECE R117 Tyres with regard to rolling sound emissions

Calendar of meeting of GRB for 2009

49th 16-18 February, 2009

50th 1-3 September, 2009

<Main Topics>

New Test Methods(R41/R51) are being drafted considering the Urban driving conditions

Revision of R41/51



WP29/GRB discussed on a issue **what a reason why sufficient effect in reduction of traffic noise is not shown however noise limit value for new vehicle was reduced.**

EU commission also point out this issue in their directive 2007/34/EC, it mentions,

Since the entry into force of Directive 70/157/EEC of 6 February 1970, the noise limits for motor vehicles have been reduced several times, most recently in 1995.

The last reduction (R41/03,R51/02) did not have the expected effects and subsequent studies have shown that the measurement method no longer reflects the real life driving behavior.

It is therefore necessary to introduce **a new test cycle and bring the driving conditions for carrying out the noise test closer into line with real life driving operations.** The new test cycle is contained in UN/ECE Regulation No 51, 02 series of amendments (3).



Typical Driving Behaviour of a Passenger Car in Urban Traffic

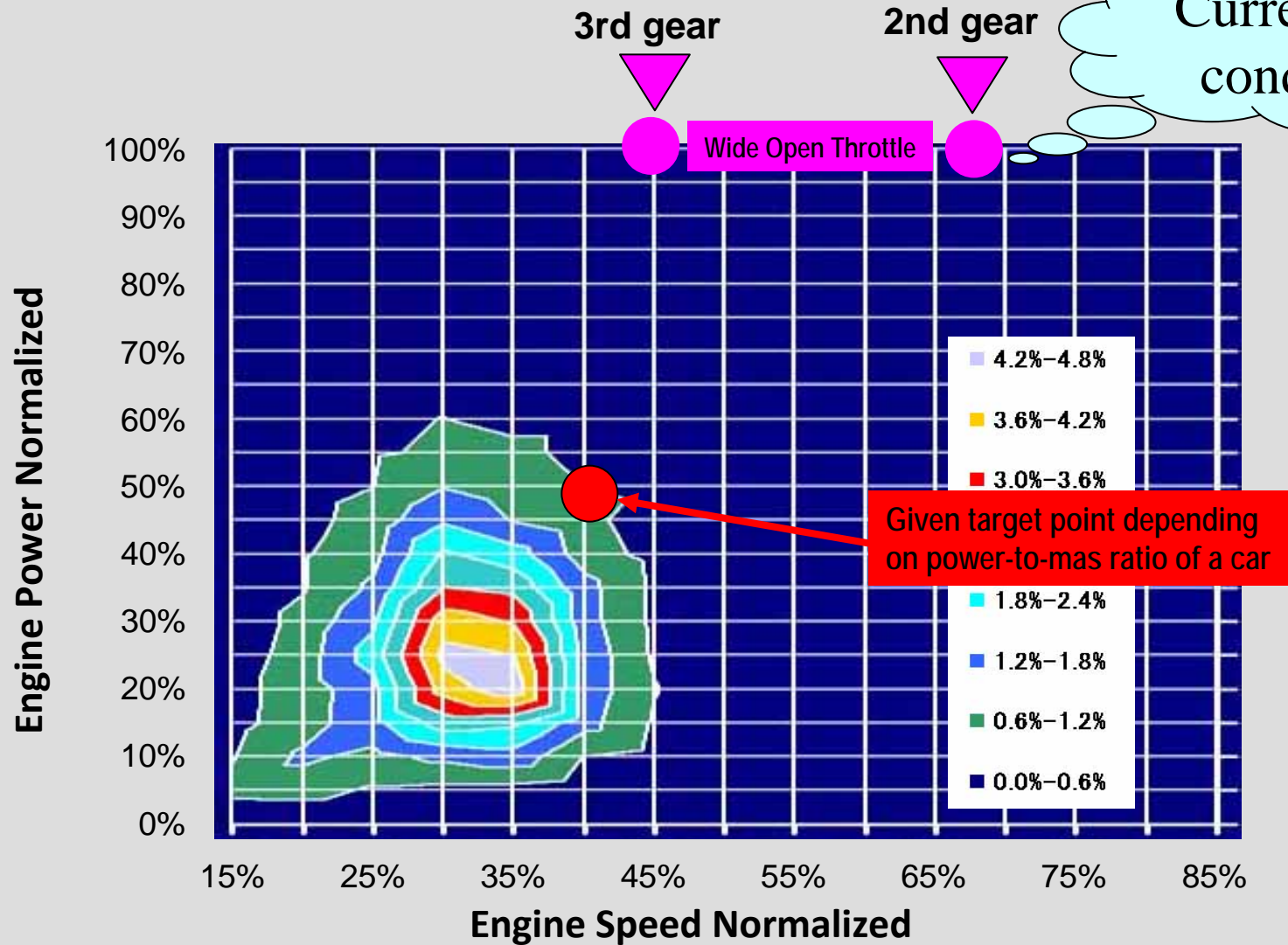

Statistical Background for a New Test Procedure

Driving Conditions in Urban Traffic



[FINAL DRAFT]

ECONOMIC COMMISSION FOR EUROPE INLAND TRANSPORT COMMITTEE

World Forum for Harmonization of Vehicle Regulations (WP.29)

(One-hundred-and-thirty-eighth session, 7-10 March 2006, agenda item 4.2.11.)

**PROPOSAL FOR SUPPLEMENT 4 TO THE 02 SERIES OF AMENDMENTS TO REGULATION No. 51
(Noise emissions)**

Transmitted by the representative of the European Community (EC)

Note: The text reproduced below was prepared by the representative of the EC with **a view to introduce an additional test method for noise of motor vehicles which is intended to reproduce the noise levels generated by vehicles during normal driving in urban traffic.**

This document is an alternative proposal to ECE/TRANS/WP.29/2006/4.

This document is a working document circulated for discussion and comments.

The use of this document for other purposes is the entire responsibility of the user.

Documents are also available via the INTERNET: <http://www.unece.org/trans/main/welcwp29.htm>

The list of Contents,

Annex 3, amended to read:

**“Annex 3 - Methods and instruments for measuring the noise made by motor vehicles
(Measurement Method A)**

Insert new Annexes 9 and 10, to read:

"Annex 9 - Vehicle Test Data pursuant to Measurement Method B

**Annex 10 - Methods and instruments for measuring the noise made by motor vehicles
(Measurement Method B)“**

Contents



1. WP29 and GRB

2. Common Information on R41/R51

1) Vehicle categories

2) Histories

3) Application

4) Approval

5) Marking

6) COP

7) Penalties

2-1) Vehicle categories



(1) Motorcycles and Tricycles

	L1	L2	L3	L4	L5
No. of wheels	2	3	2	3 Asymmetrical	3 Symmetrical
Seating capacity	N.A.				
Vehicle mass	N.A.				
Eng. displacement	$\leq 50\text{cm}^3$		$> 50\text{cm}^3$		
Type of body	N.A.				
Other criteria	Max.speed $\leq 50\text{kmh}$		Max.speed $> 50\text{kmh}$		
Applied noise regulation	R63	R9	R41-03	R9	

The **CLASSIFICATION OF VEHICLES** is specified by the Annex 4.



2-1) Vehicle categories



(2) Passenger cars:

CATEGORY M - POWER-DRIVEN VEHICLES HAVING AT LEAST FOUR WHEELS AND USED FOR THE CARRIAGE OF PASSENGERS

	M1	M2	M3
No. of wheels	4≤		
Seating capacity	≤9	9<	9<
Vehicle mass	N.A.	GVM(*) ≤ 5 tons	5 tons < GVM
Applied noise regulation	R51-02		

(*)GVM : Gross Vehicle Mass

2-1) Vehicle categories



(3) Trucks:

CATEGORY N:

POWER-DRIVEN VEHICLES HAVING AT LEAST FOUR WHEELS AND USED FOR THE CARRIAGE OF GOODS

	N1	N2	N3
No. of wheels	4≤		
Seating capacity	N.A.		
Vehicle mass	GVM≤ 3.5 ton	3.5 <GVM≤ 12 ton	12 ton<GVM
Applied noise regulation	R51-02		

2-2) Histories



(1) R41

Series	R41	R41-01	R41-02	R41-03
Date of entry into force	Jun 1, 1980	July 24, 1984	Apr. 1, 1994	Feb 5 2000
Limit value	86 (<500cc)	83 (<175cc)	80 (<175cc)	80 (<175cc)
	85 (350<≤500cc)	80 (80<≤175cc)	77 (80<≤175cc)	77 (80<≤175cc)
	83 (175<≤350cc)	77 (≤80)	75 (≤80)	75 (≤80)
Updated contents • ; Modified + ; Added	80 (80<≤175cc)	+ Over-run(*) provision + Transitional provisions • Classification • Gear choice • Approach speed	+ Durability requirement for silencer using fibrous materials + Providing stationary noise information on vehicle • Engine speed of stationary noise test	+ ISO road surface + Back ground noise coefficient + “E” Marking on silencing systems • Value calculation • Over-run provision
	78 (≤80)			

(*)Over-run means the engine speed at the exit of acceleration area exceeding defined value.

2-2) History



(2) R51

Series	R51-00	R51-01	R51-02
Date of entry into force	July 15. 1982	Apr 27. 1988	Apr 18. 2005
Limit value	[dB(A)]	[dB(A)]	[dB(A)]
M1	80	77	74
N3 (>150kW)	88	84	80
Updated contents <ul style="list-style-type: none"> • ; Modified + ; Added 		<ul style="list-style-type: none"> + Durability requirement for silencer using fibrous materials · Extra value for the limit of off-road vehicles · Excluding an external downshift for automatic transmission 	<ul style="list-style-type: none"> + ISO road surface · Test method - Over-run provision - in case of the category other than M1 and having >225kW engine · Difference between calibrations on before and after measurements; +/-0.5dB + Tolerance of approach speed; +/-1km/h + Environmental condition; <ul style="list-style-type: none"> Air temp; 0~40°C Wind speed < 5m/s

Contents of R41



REGULATION

1. Scope
2. Definitions
- 3. Application for approval**
- 4. Markings**
- 5. Approval**
6. Specifications
7. Modification and extension of the approval of the motorcycle type or the type of exhaust or silencing system(s)
- 8. Conformity of Production**
- 9. Penalties for non-conformity of production**
10. Production definitely discontinued
11. Names and addresses of technical services responsible for conducting approval tests, and of administrative departments
12. Transitional provisions

ANNEXES

Annex 1-Communication concerning the approval or extension or refusal or withdrawal of approval of production definitely discontinued of a motor cycle type with regard to noise emitted by motor cycles pursuant to Regulation No. 41

Annex 2-Arrangements of approval marks

Annex 3-Methods and instruments for measuring the noise made by motor cycles

Annex 4-Test track specifications

Annex 5-Exhaust system (silencer)

Annex 6-Maximum limits of sound level (new motor cycles)

Contents of R51



REGULATION

1. Scope
2. Definitions
- 3. Application for approval**
- 4. Markings**
- 5. Approval**
6. Specifications
7. Modification and extension of approval of a vehicle type
- 8. Conformity of Production**
- 9. Penalties for non-conformity of production**
10. Production definitely discontinued
11. Transitional provisions
12. Names and addresses of technical services responsible for conducting approval tests, and of administrative departments

ANNEXES

- Annex 1 - Communication concerning the approval or extension or refusal or withdrawal of approval or production definitely discontinued of a vehicle type with regard to its noise emission pursuant to Regulation No.51
- Annex 2 - Arrangements of the approval mark
- Annex 3 - Methods and instruments for measuring the noise made by motor vehicles**
- Annex 4 - Classification of vehicles
- Annex 5 - Exhaust systems containing fibrous materials
- Annex 6 - Compressed air noise
- Annex 7 - Checks on conformity of production
- Annex 8 - Specifications for the test site

Overview of presentations

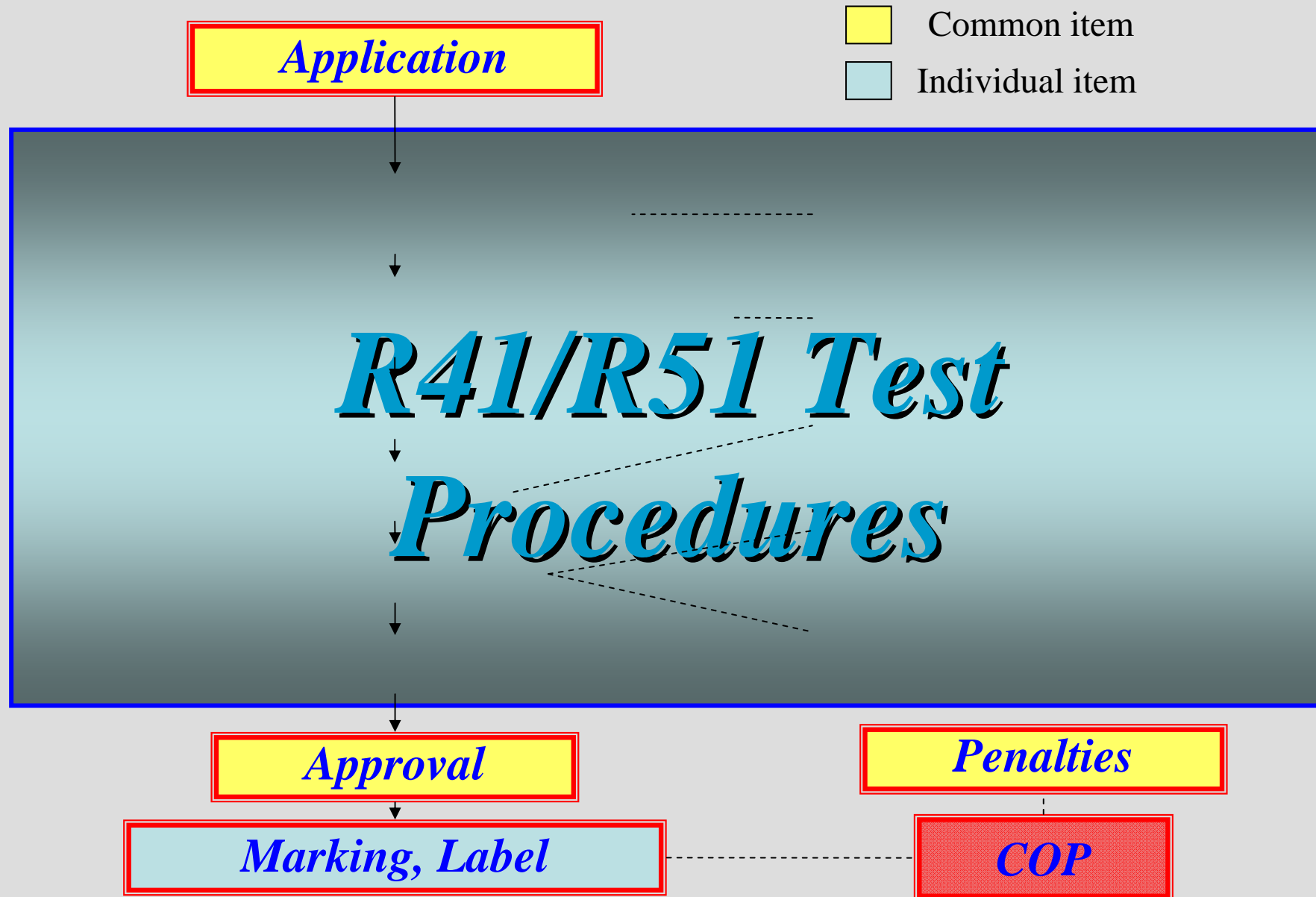

2-3) Application for Approval



- 3.1. The application for approval of a vehicle type with regard to noise shall be submitted by its manufacturer or by his duly accredited representative.

- 3.2. It shall be accompanied by the under mentioned documents and the following particulars in triplicate:
 - 3.2.1. a description of the vehicle type with regard to the items mentioned in paragraph 2.2. above. The numbers and/or symbols identifying the engine type and the vehicle type shall be specified;

 - 3.2.2. a list of the components, duly identified, constituting the noise reduction system;

2-3) Application for Approval



3.2.3. a drawing of the assembled noise reduction system and an indication of its position on the vehicle;

3.2.4. detailed drawings of each component to enable it to be easily located and identified, and a specification of the materials used.

3.5. The competent authority shall verify the existence of satisfactory arrangements for ensuring effective control of the conformity of production before type approval is granted.

2-3) Application document



Annex 1 : Contents to be filled in application documents are defined in a communication form.

S/CEC/324
Rev.1/ASB.43/Rev.1
S/CEC/TRANS/333
Regulation No. 41
Annex 1
page 14

Annex 1
COMMUNICATION
(Maximum format: A4 (210 x 297 mm))

issued by: Name of administration:
.....
.....
.....



concerning: / APPROVAL GRANTED
APPROVAL EXTENDED
APPROVAL REFUSED
APPROVAL WITHDRAWN
PRODUCTION DEFINITELY DISCONTINUED

of a motor cycle type with regard to noise emitted by motor cycles pursuant to Regulation No. 41

Approval No. Extension No.

1. Trade name or mark of the motor cycle

2. Motor cycle type

3. Manufacturer's name and address

4. If applicable, name and address of manufacturer's representative

5. Kind of engine /

6. Cycles: two-stroke or four-stroke (if applicable)

S/CEC/324
Rev.1/ASB.43/Rev.1
S/CEC/TRANS/333
Regulation No. 41
Annex 1
page 15

7. Cylinder capacity

8. Engine power (state how measured)

9. Speed at which maximum power is developed (rpm)

10. Number of gears

11. Gears used

12. Final drive ratio(s)

13. Type and dimensions of tyres

14. Maximum permissible gross weight

15. Brief description of the silencing system

16. Load conditions of motor cycle during test

17. For stationary motor cycle test: location and orientation of the microphone (by reference to diagrams in Appendix to Annex 3)

18. Sound levels:
Motor cycle in motiondB(A) at steady speed before acceleration of ... km/h, rotation speed of the engine ... rpm.
Motor cycle stationarydB(A) with engine running at rpm.

19. Deviations in calibration of sound level meter

20. Motor cycle submitted for approval on

21. Technical service responsible for conducting approval tests

22. Date of report issued by that service

23. Number of report issued by that service

24. Approval granted/extended/refused/withdrawn /

25. Position of approval mark on the motor cycle

26. Place

27. Date

28. Signature

29. The following documents, bearing the approval number shown above, are annexed

2-3) Application document



General information

- Trade name or mark of the vehicle
- Vehicle Type
- Name and address of vehicle manufacturer
- Engine Type
- Engine model
- Name and address of engine manufacturer

2-3) Application document (cont'd)



Vehicle information

- Maximum permissible mass
- Transmission type
- Number of gears
- Final drive ratio (For motorcycle)

Engine information

- Rated maximum engine power
- Kind of engine
- Cycles
- Cylinder capacity

2-3) Application document (cont'd)



Equipments information

>Exhaust silencer:

Manufacturer, Model, Type: in accordance with drawing No.

>Intake silencer

Manufacturer, Model, Type: in accordance with drawing No.

>Type and dimensions of tires

Diagrams and plans of

>The engine and the noise reduction system

Photographs

>The engine and the noise reduction system

>List of components constituting the noise reduction system.

Noise reduction system of passenger car



2.5. "Noise reduction system component" means one of the individual constituent parts whose assembly constitutes the noise reduction system. These components are, in particular: the exhaust pipings, the expansion chamber(s), the silencer(s) proper.

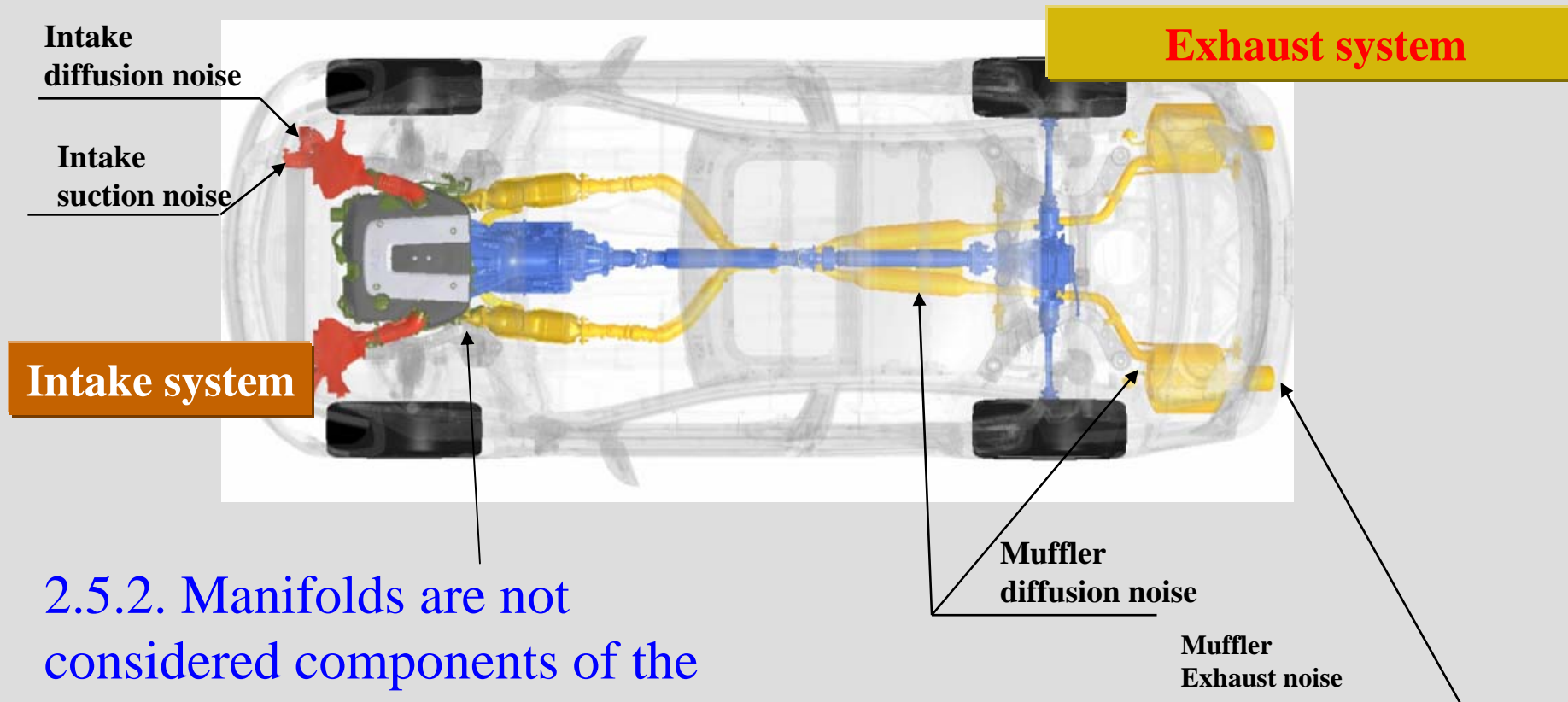

2.5.2. Manifolds are not considered components of the noise reduction system.

Noise reduction system of motorcycle

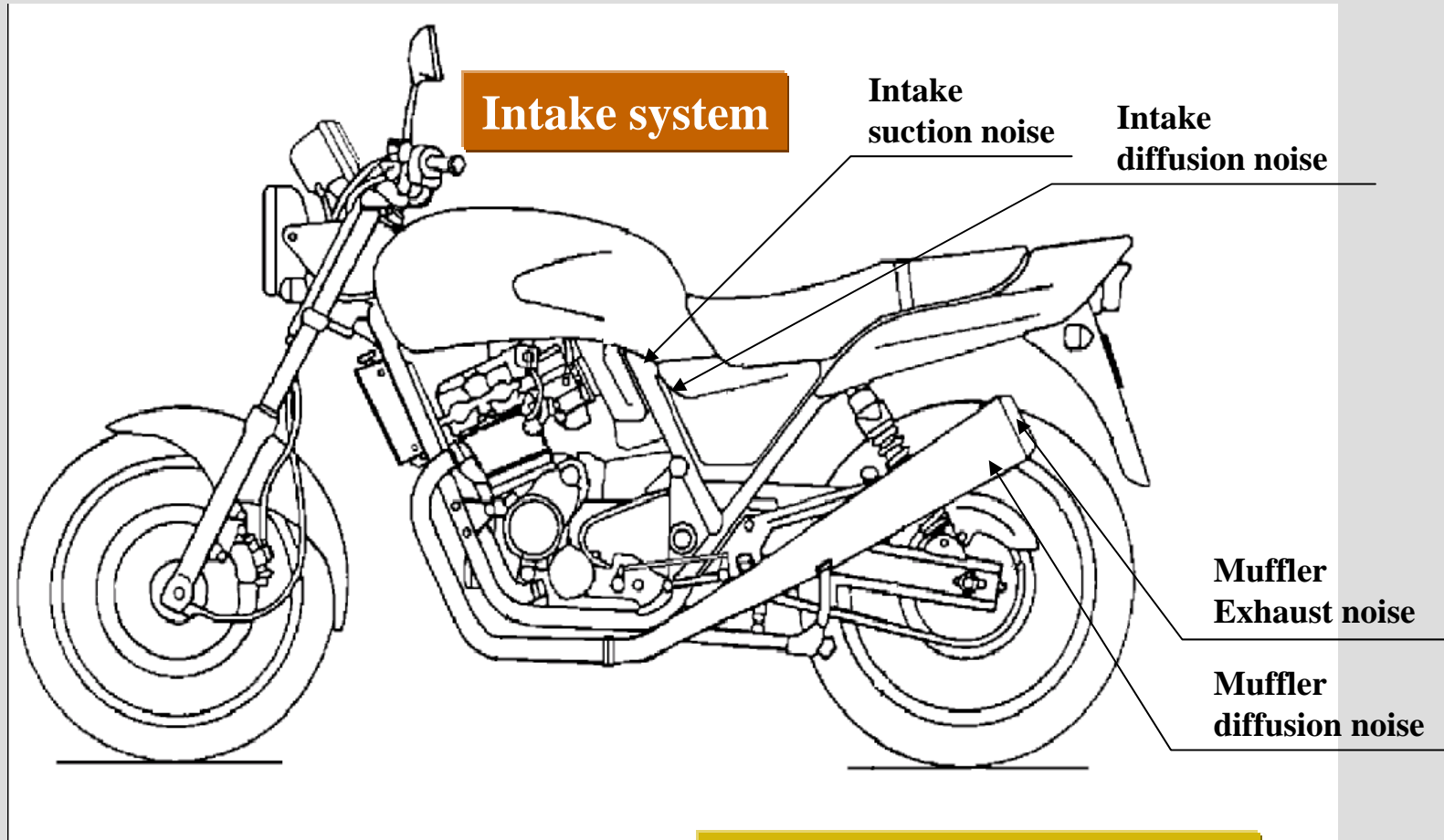

Intake system

**Intake
suction noise**

**Intake
diffusion noise**

**Muffler
Exhaust noise**

**Muffler
diffusion noise**

Exhaust system

Overview of presentations

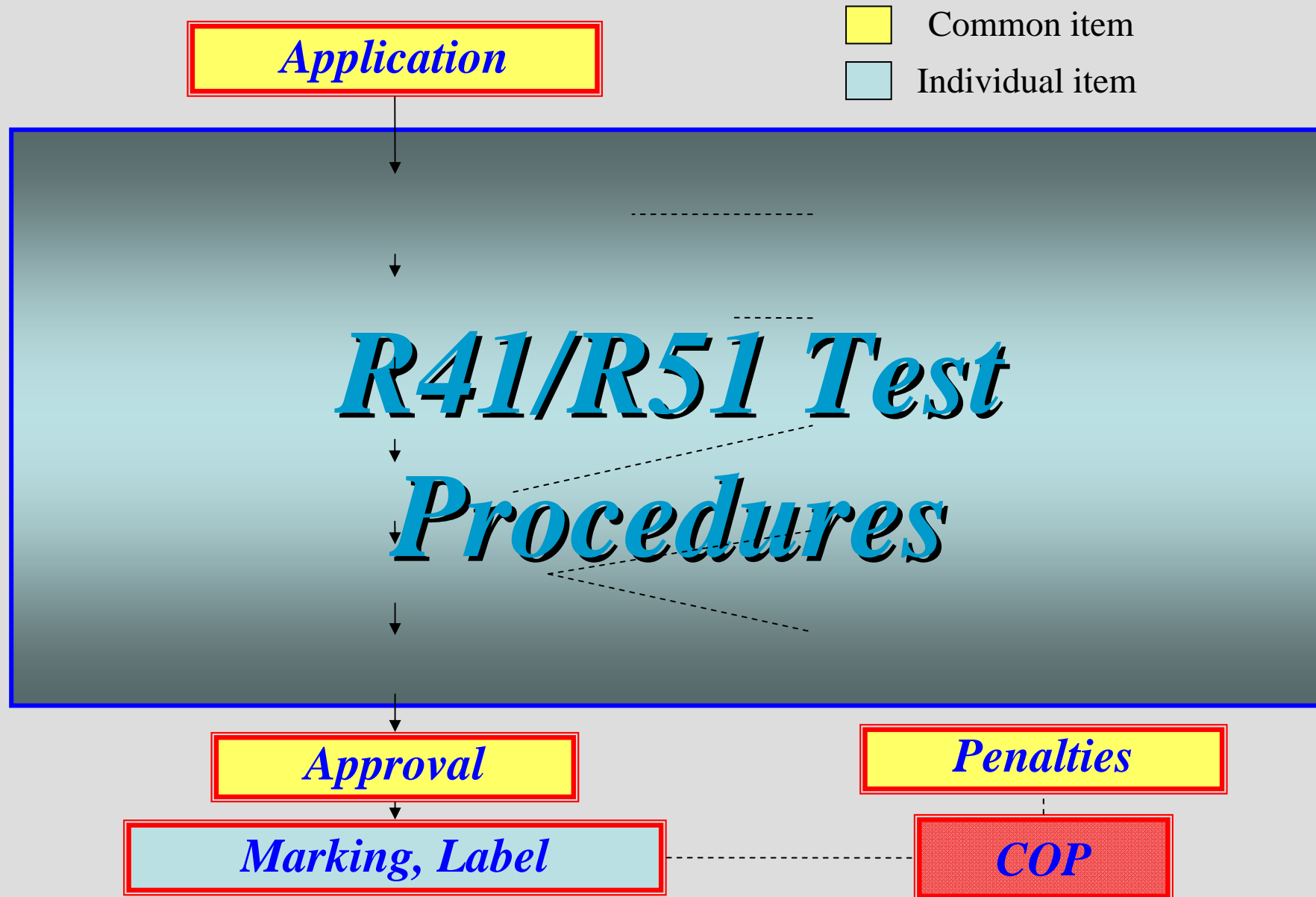

2-4) Marking (R41 / R51)



- 4.1. The components of the noise reduction system,
excluding fixing hardware and piping, shall bear:
 - 4.1.1. the trade name or mark of the manufacturer of the noise reduction system and of its components; and
 - 4.1.2. the manufacturer's trade description;

(4.1.3 , 4.1.4 , 4.1.5 for R41 = see next slide)
- 4.2. These markings shall be clearly legible and be indelible even after fitting.
- 4.3. A component may carry several approval numbers if it has been approved as component of several replacement silencing systems.

2-4) Marking (only for R41)



4.1.3. the approval mark and the ECE approval number according to annex 2 of the Regulation. The approval number must correspond to the number of the ECE type approval certificate issued for the type of exhaust or silencing system in question.

4.1.4. All original silencers must be bear the 'E' mark followed the identification of the country which granted the component type-approval. This reference must be legible and indelible and also visible in the position at which it is to be fitted.

4.1.5. Any packing of original replacement silencer systems must be marked legibly with the words 'original part' and the make and type references integrated together with the 'E' mark and also the reference of the country of origin.

Overview of presentations

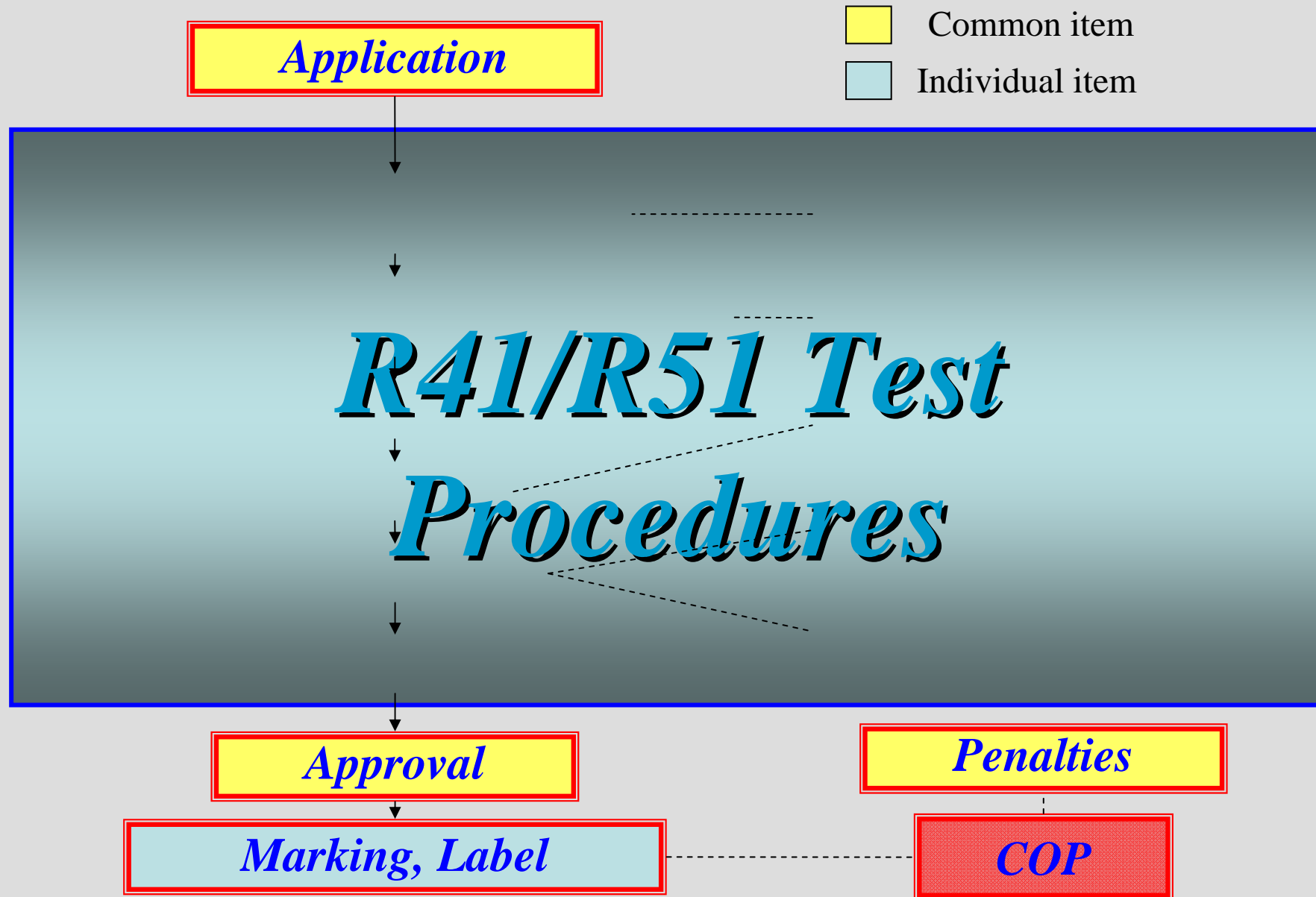

2-5) APPROVAL



5.1. *If the vehicle type* submitted for approval pursuant to this Regulation *meets the requirements* of paragraph 6. and 7. below, *approval of that vehicle type shall be granted.*



5.2. *An approval number shall be assigned to each type approved.*

Its first two digits (at present 02 corresponding to the 02 series of amendments which entered into force on 18 April 1995) shall indicate the series of amendments incorporating the most recent major technical amendments made to the Regulation at the time of issue of the approval.

The same Contracting Party may *not assign the same number* to the same vehicle type equipped with another type of noise reduction system or to another vehicle type.

5.3. *Notice of approval* or of extension or of refusal or withdrawal of approval or Of production definitely discontinued of a vehicle type pursuant to this Regulation *shall be communicated to the Parties to the Agreement applying this Regulation*, by means of a form conforming to *the model in annex 1 to this Regulation.* (see annex 1 = next slide)

Annex 1: COMMUNICATION



COMMUNICATION

issued by: Name of administration:

.....

.....

.....

2/; Strike out what does not apply.

concerning:2/

APPROVAL GRANTED

~~APPROVAL EXTENDED~~

~~APPROVAL REFUSED~~

~~APPROVAL WITHDRAWN~~

~~PRODUCTION DEFINITELY DISCONTINUED~~

of a vehicle type with regard to its noise emission pursuant to ECE Regulation No. 51.

Approval No.:

Extension No.:

5.4. There shall be affixed, conspicuously and in a readily accessible place specified on the approval form, to every vehicle conforming to a vehicle type approved under this Regulation an international approval mark consisting of:

5.4.1. a circle surrounding the letter "E" followed by the distinguishing number of the country which has granted approval2/;

5.4.2. the number of this Regulation, followed by the letter "R", a dash and the approval number to the right of the circle prescribed in paragraph 5.4.1.

5.5. If the vehicle conforms

5.6. **The approval mark shall be clearly legible and be indelible.**

5.7. The approval mark shall be placed close to or on the vehicle data plate affixed by the manufacturer.

5.8. **Annex 2** to this Regulation gives

examples of arrangements of the approval mark.



Let's see Annex 2

Distinguishing number



2/

1 for Germany, 2 for France, 3 for Italy, 4 for the Netherlands, 5 for Sweden, 6 for Belgium, 7 for Hungary, 8 for the Czech Republic, 9 for Spain, 10 for Yugoslavia, 11 for the United Kingdom, 12 for Austria, 13 for Luxembourg, 14 for Switzerland, 15 (vacant), 16 for Norway, 17 for Finland, 18 for Denmark, 19 for Romania, 20 for Poland, 21 for Portugal, 22 for the Russian Federation, 23 for Greece, 24 for Ireland, 25 for Croatia, 26 for Slovenia, 27 for Slovakia, 28 for Belarus, 29 for Estonia, 30 (vacant), 31 for Bosnia and Herzegovina, 32 for Latvia, 33 (vacant), 34 for Bulgaria, 35-36 (vacant), 37 for Turkey, 38-39 (vacant), 40 for The former Yugoslav Republic of Macedonia, 41 (vacant), 42 for the European Community (Approvals are granted by its Member States using their respective ECE symbol),

43 for Japan, **44 (vacant)**, 45 for Australia, 46 for Ukraine and 47 for South Africa.

Subsequent numbers shall be assigned to other countries in the chronological order in which they ratify or accede to the Agreement

Concerning the Adoption of Uniform Technical Prescriptions for Wheeled Vehicles, Equipment and Parts which can be Fitted and/or be Used on Wheeled Vehicles and the Conditions for Reciprocal Recognition of Approvals Granted on the Basis of these Prescriptions, and **the numbers** thus assigned **shall be communicated by the Secretary-General of the United Nations to the Contracting Parties to the Agreement.**

Approval label



Annex 2 :



The above approval mark affixed to a motor cycle shows that the motor cycle type concerned has, with regard to noise,

been approved in the Netherlands (E 4)

pursuant to Regulation No. 41 under

approval number 032439.

The approval number indicates that the approval was granted according to the requirements of Regulation No. 41 as amended by the 03 series of amendments.

Approval label

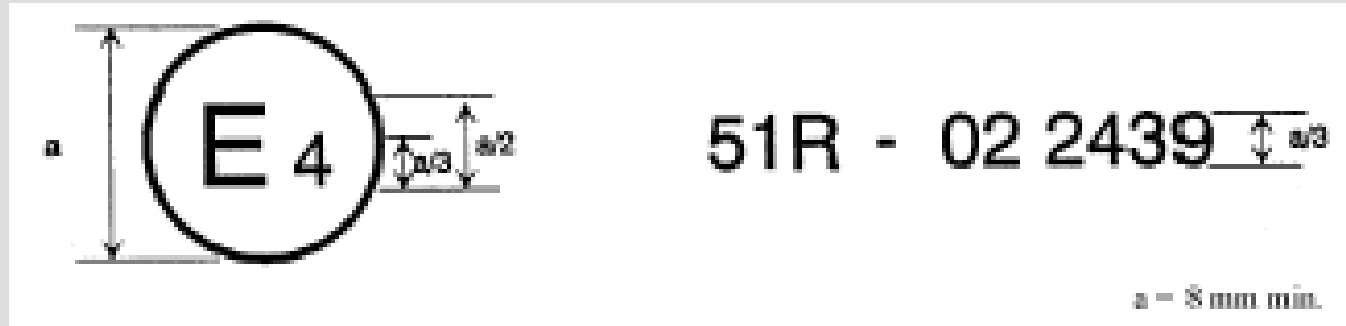

The above approval mark affixed to a vehicle shows that the vehicle type concerned has, with regard to its noise emission, been approved in the Netherlands (E 4) pursuant to Regulation No. 51 under approval No.022439.

The first two digits of the approval number indicate that Regulation No. 51 already included the 02 series of amendments when the approval was granted.

< Question : What does the bellow approval mark mean? >

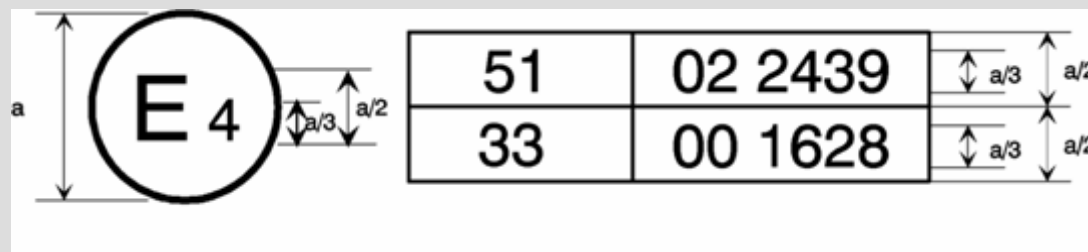

Overview of presentations

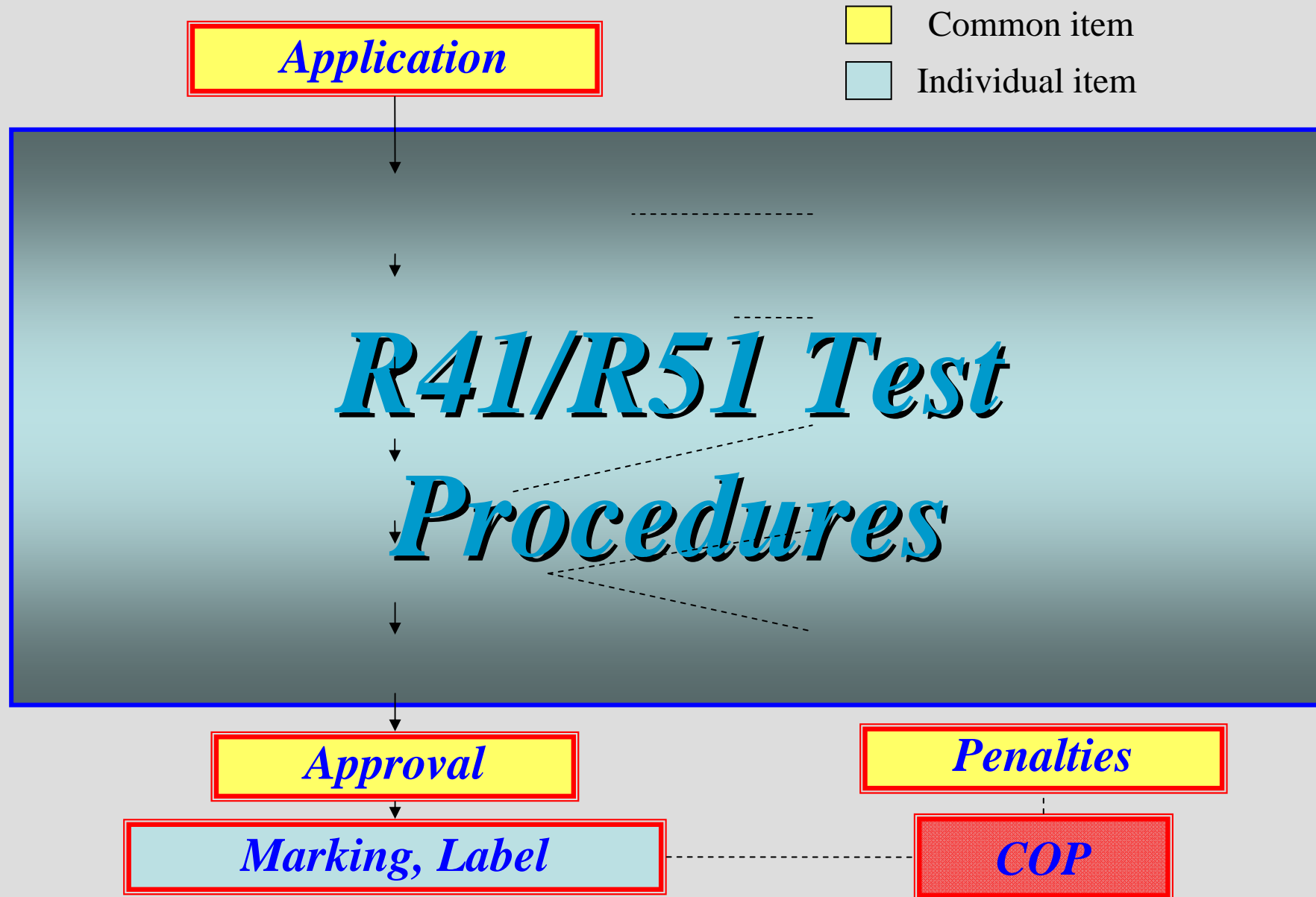

COP : CONFORMITY OF PRODUCTION



Basic Concept of COP

8.1. Vehicles approved to this Regulation shall be so manufactured as to conform to the type approved by meeting the requirements set forth in paragraph 6. above.

Aim

8.2. In order to verify that the requirements of paragraph 8.1. are met, suitable controls of the production shall be carried out (by Manufacturer).

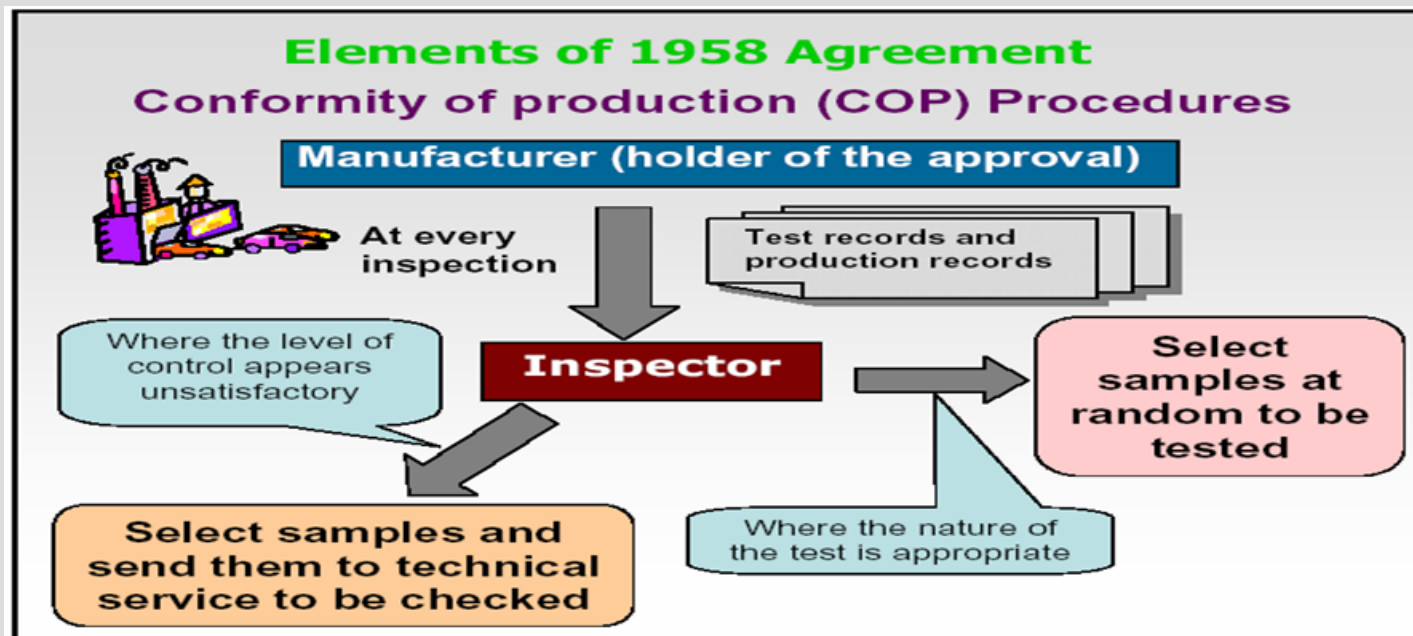

2-6) COP



Activity

8.3. *The holder of the approval* shall in particular

8.3.1. ensure existence of procedures for the effective control of the quality of products;

8.3.2. have access to the control equipment necessary for checking the conformity of each approved type;

8.3.3. ensure that data of test results are recorded and that annexed documents shall remain available for a period to be determined in accordance with the administrative service;

8.3.4. analyze the results of each type of test, in order to verify and ensure the stability of the product characteristics making allowance for variation of an industrial production;

2-6) COP



Activity

- 8.3.5. ensure that for each type of product at least the tests prescribed in annex 7 to this Regulation are carried out;
- 8.3.6. ensure that any sampling or test pieces giving evidence of non-conformity with the type of test considered shall give rise to another sampling and another test. All the necessary steps shall be taken to re-establish the conformity of the corresponding production.

See annex 7 :

CHECKS ON CONFORMITY OF PRODUCTION

CHECKS ON CONFORMITY OF PRODUCTION

1. General

These requirements are consistent with the test to be held to check conformity of production according to paragraphs 8.3.5. and 8.4.3. of this Regulation.

2. Testing procedure

The test site and measuring instruments shall be those as described in annex 3.

3. Sampling

One vehicle has to be chosen. If after the test of paragraph 4.1. the vehicle is not considered to conform to the requirements of this Regulation, two more vehicles have to be tested.

CHECKS ON CONFORMITY OF PRODUCTION

4. Evaluation of the results

- 4.1. **If the sound level of the vehicle** tested pursuant to paragraphs 1 and 2 does **not exceed by more than 1 dB (A) the limit value** prescribed in paragraph 6.2.2. of this Regulation, for measurement according to paragraph 2.1. above, and in paragraph 3 of annex 6 to this Regulation, for measurement according to paragraph 2.2. above, **the vehicle type shall be considered to conform to the requirements of this Regulation.**
- 4.2. **If the vehicle tested** according to paragraph 4.1. **does not satisfy the requirements** laid down in that paragraph, **two more vehicles of the same type have to be tested** pursuant to paragraphs 1 and 2.

CHECKS ON CONFORMITY OF PRODUCTION

4.3. **If the sound level of the second and/or third vehicle of paragraph 4.2. exceeds by more than 1 dB(A) the limit values prescribed in paragraph 6.2.2. of this Regulation, the vehicle type shall be considered not to conform to the requirements of this Regulation and the manufacturer shall take the necessary measures to re-establish the conformity.**

Be careful :



for **R41:**

In order to test conformity as required above, a sample motorcycle will be taken from the production line of the type approved pursuant to this Regulation.

Production will be regarded as conforming to the provisions

of this Regulation if the sound level measured using the method described in annex 3

does not exceed more than 3 dB(A) the value measured at the time of type-approval,

nor by more than 1 dB(A) the limits

laid down in annex 6 of this Regulation.

2-6) COP: CONFORMITY OF PRODUCTION



8.4. **The competent authority** which has granted type-approval may at any time verify the conformity control method applicable to each production unit.

8.4.1. In every inspection the test books and production survey records shall be presented to the visiting inspector.

8.4.2. **The inspector** may take samples at random which will be tested in the manufacturer's laboratory.

The minimum number of samples may be determined according to the results of the manufacturer's own verification.

8.4.3. When the quality level appears unsatisfactory or when it seems necessary to verify the validity of the tests carried out in application of paragraph 8.4.2. the inspector shall select samples to be sent to the technical service which has conducted the type approval tests.

2-6) COP: CONFORMITY OF PRODUCTION



8.4.4. **The competent authority** may carry out any test prescribed in this Regulation.

8.4.5. **The normal frequency of inspections** by the competent authority **shall be one every two years.**

If unsatisfactory results are recorded during one of these visits, ***the competent authority*** **shall ensure that, all necessary steps are taken to re-establish the conformity of production as rapidly as possible.**

2-7) Penalties



9. PENALTIES FOR NON-CONFORMITY OF PRODUCTION

9.1. The approval granted in respect of a vehicle type pursuant to this Regulation may be withdrawn if the requirements set forth above are not met.

9.2. If a Contracting Party to the Agreement applying this Regulation withdraws an approval it has previously granted, it shall forthwith so notify the other Contracting Parties applying this Regulation, by means of a communication form conforming to the model in annex 1 to this Regulation.

Annex 1: COMMUNICATION

A black arrow points from the text 'Annex 1: COMMUNICATION' up and to the right towards the word 'communication' in the text of paragraph 9.2.

Annex 1: COMMUNICATION



COMMUNICATION

issued by: Name of administration:

.....
.....
.....

2/ Strike out what does not apply.

concerning:2/

~~APPROVAL GRANTED~~

~~APPROVAL EXTENDED~~

~~APPROVAL REFUSED~~

APPROVAL WITHDRAWN

~~PRODUCTION DEFINITELY DISCONTINUED~~

of a vehicle type with regard to its noise emission pursuant to ECE Regulation No. 51.

Approval No.:

Extension No.:

Overview of presentations

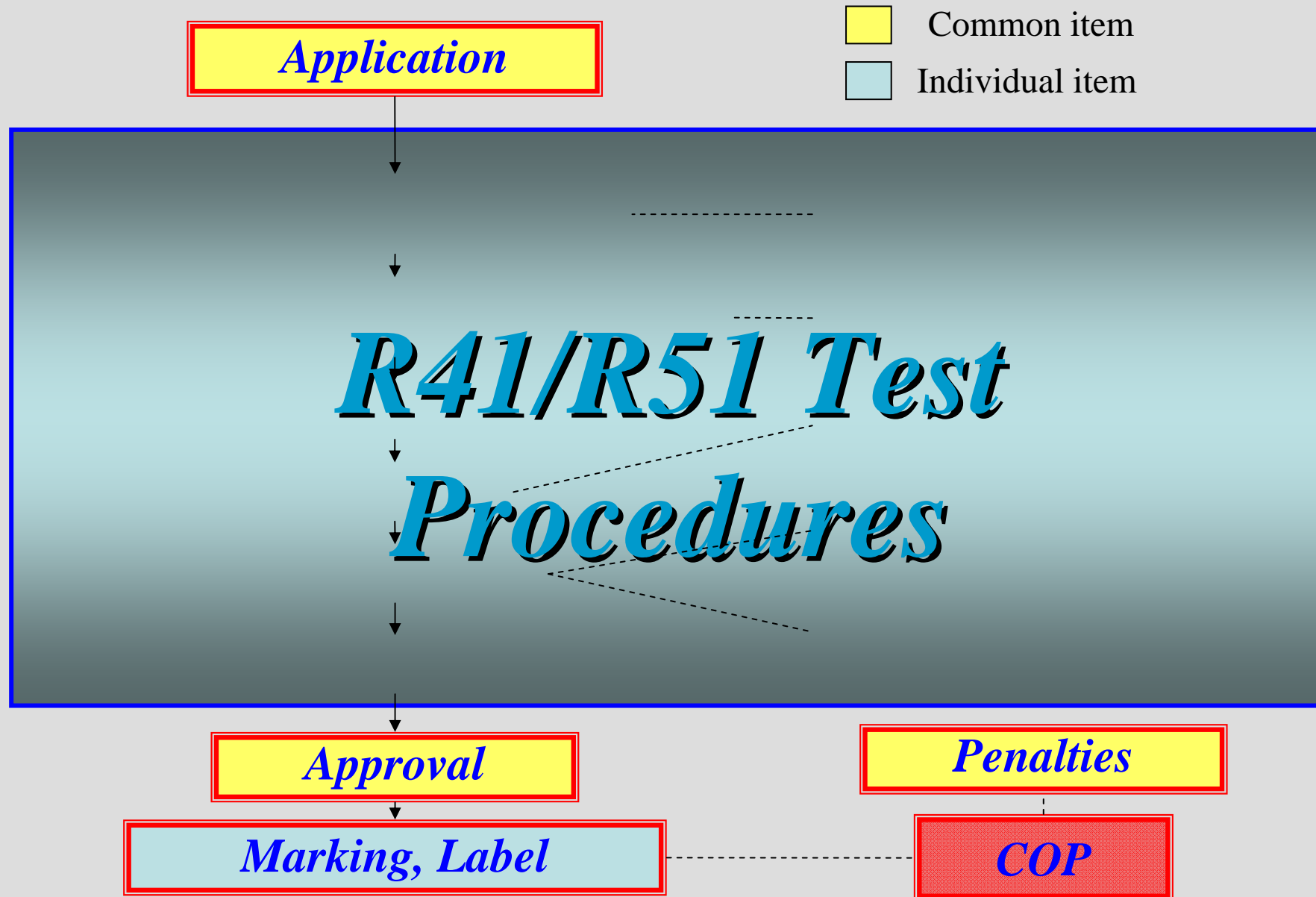

***Thank you very much
for your attention***

The background of the slide is a photograph of a park during autumn. The trees have yellow and orange leaves, and the ground is covered with fallen leaves. A black lamppost is visible in the foreground on the left.

**ECE R41, R51
NOISE on motorcycles and passenger cars**

S. Yonezawa
JASIC Noise-sub committee

Overview of presentations

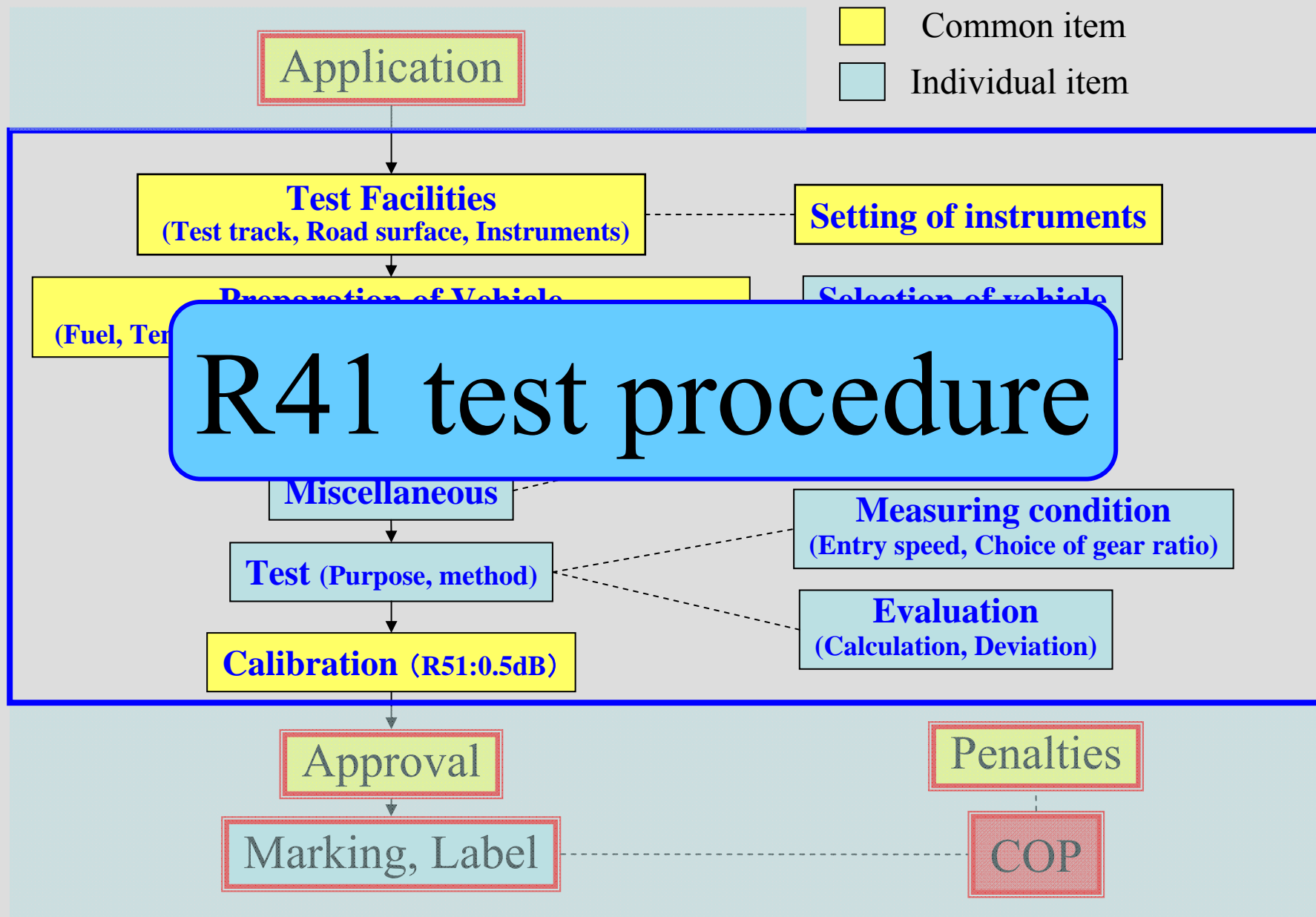

Test procedures



Methods of measurement

The noise submitted for approval shall be measured by the two methods

The motorcycle in motion

The motorcycle when stationary

The two values measured shall be entered in the test report and on a form conforming to the model in Annex 1 to this Regulation.

Test procedures



Methods of measurement

The noise submitted for approval shall be measured by **the two methods**

The motorcycle in motion

The motorcycle when stationary

The two values measured shall be entered in the test report and on a form conforming to the model in Annex 1 to this Regulation.

We call as

Acceleration noise (test)

Purpose of noise from vehicle in motion



- Aim of noise measurements of the vehicle in motion are for **granting the ECE type approval** for motorcycles.

Test procedures



Vehicle in motion (Sample)



Test procedures



Methods of measurement

The noise submitted for approval shall be measured by the two methods

The motorcycle in motion

The motorcycle when stationary

The two values measured shall be entered in the test report and on a form conforming to the model in Annex 1 to this Regulation.

We call as

Stationary noise (test)

Purpose of stationary noise



Aim of stationary noise test is mentioned in UN/ECE /WP29 RE3.

1.5.1.2. Methods of measuring the sound level.

..... **The test on the vehicle when stationary** may usefully be taken as a reference value by technical services wishing **to use this method to check vehicles in service.**

.....

1.5.2.2. In view of the tolerances of measuring instruments, the disturbances that may occur at the time of measurement and the scatter of measurements for vehicles of the same type, it will
TRANS/WP.29/78/Rev.1 be **necessary to allow for a margin of 5 dB(A) in comparison with the corresponding value recorded at the time of the type approval.**

in use noise enforcement in national regulation level.

It may be used with at least **5dB for margin.**

Purpose



- Example of enforcement using relative values.

Type approval

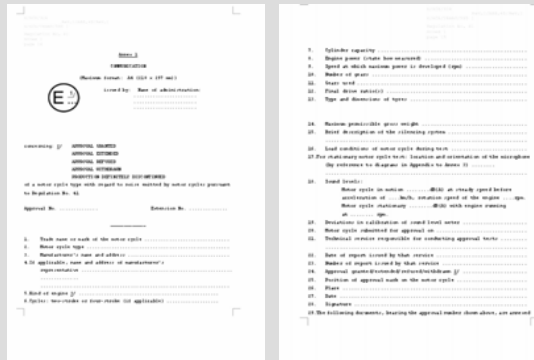
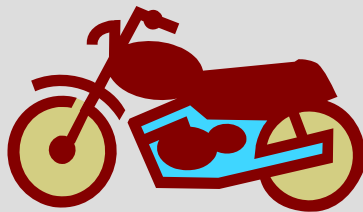

80dB / 4000rpm

ABC Motor Co.,LTD
Noise : 80dB / 4000rpm

See paragraph 6.1.3

Vehicle in use

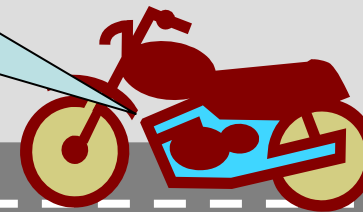

If regulation accepts stationary noise with **5dB** of a margin to the type approval value.

Value
≤85dB

Accepted

Value
>85dB

Failed

Test procedures



Vehicle in stationary (Sample)

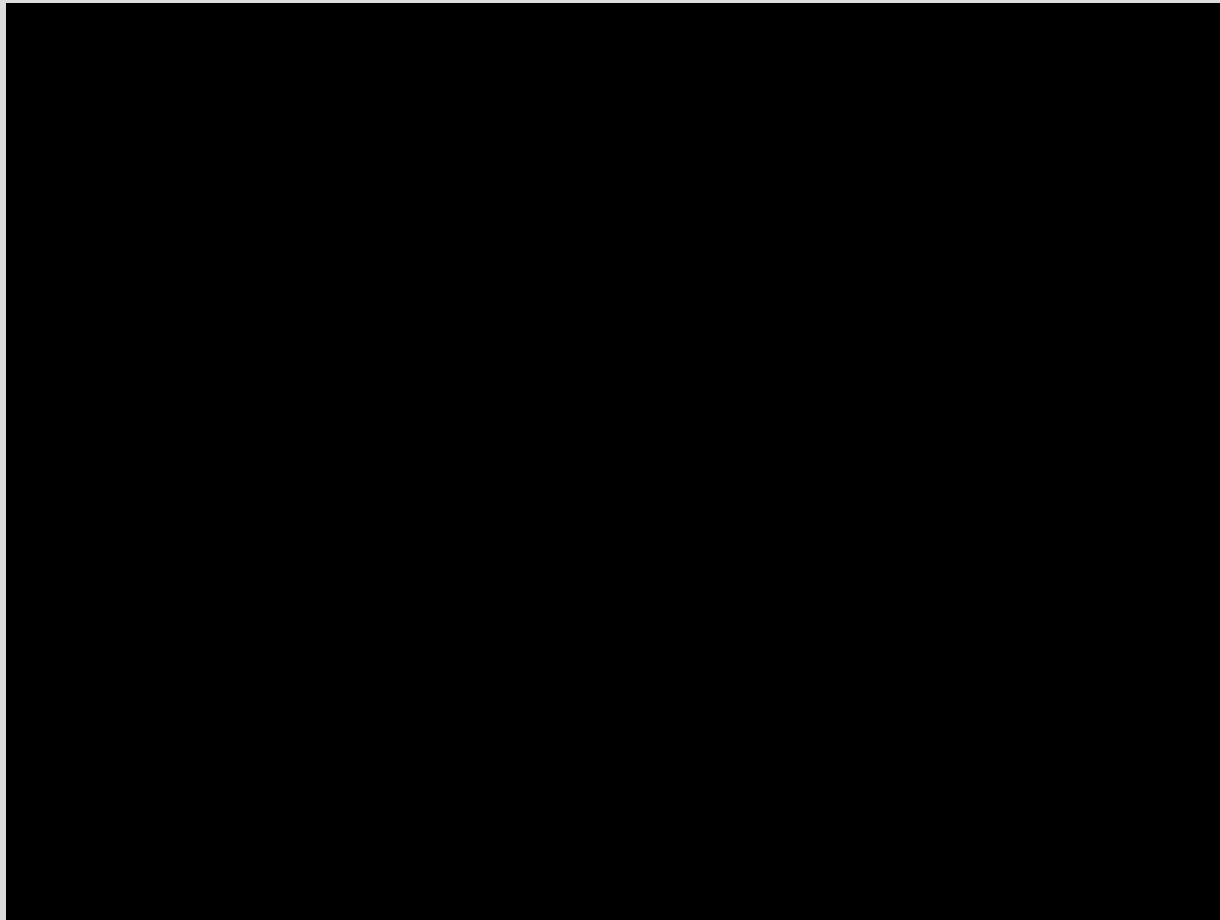

Test procedures



R41 for Motorcycles

- ◆ *Acceleration noise*
- ◆ *Stationary noise*

Overview of presentations

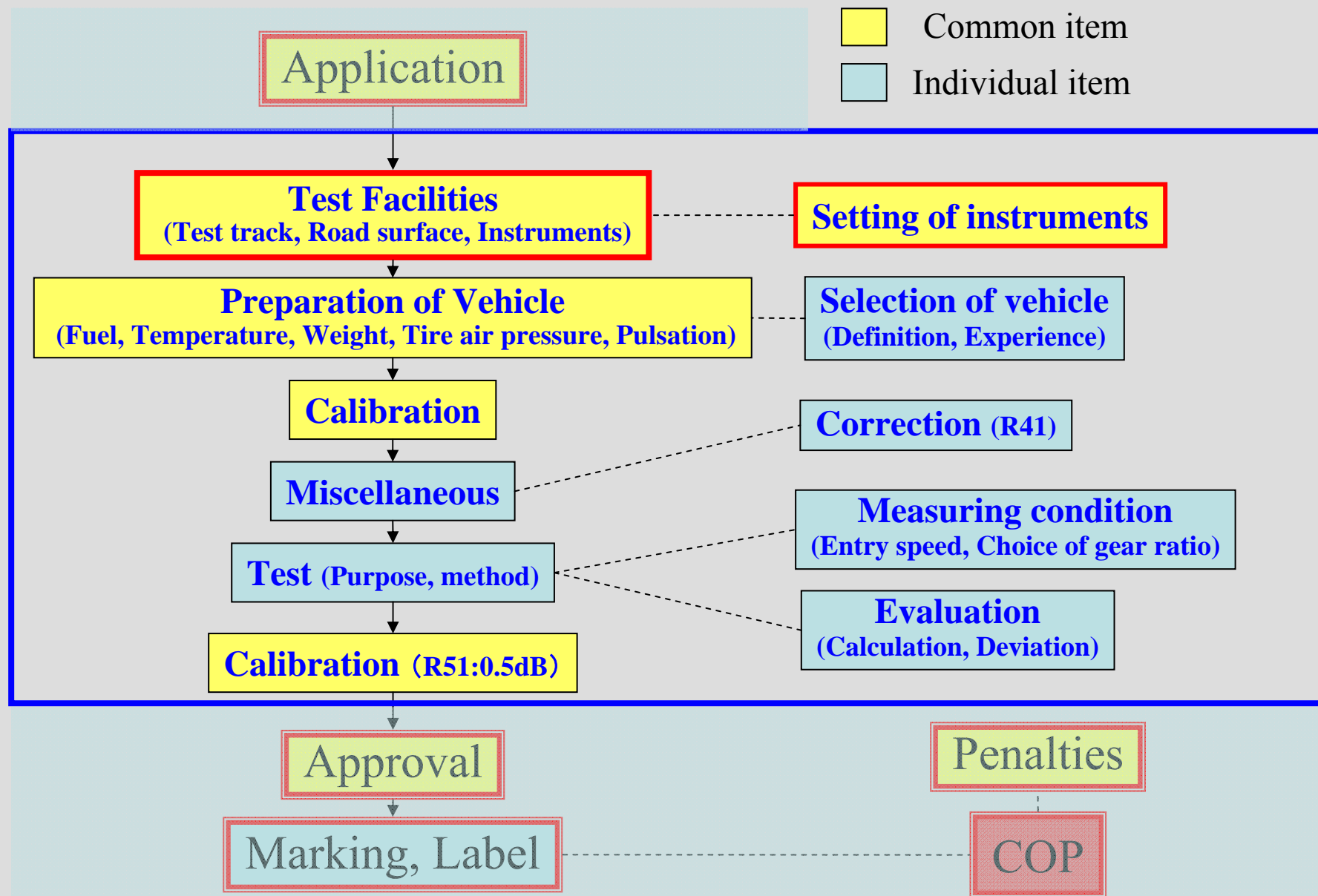

Test facilities



- Test track

The acceleration section shall be level (From AA' to BB')

Surface shall be dry.

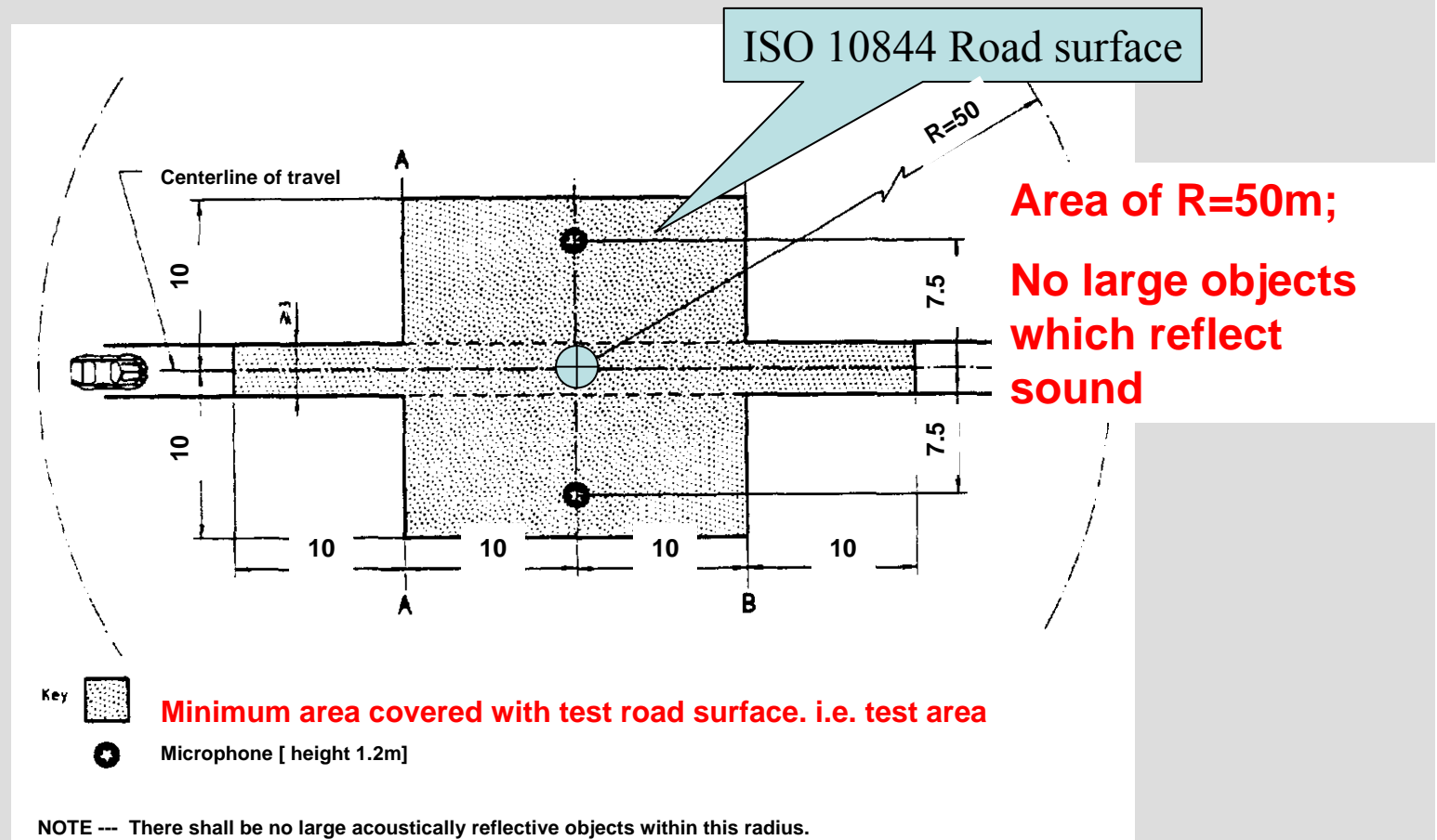

Test facilities



- Road surface

Test area shall be covered with surface specified by ISO 10844:1994 Acoustics -- Specification of test tracks for the purpose of measuring noise emitted by road vehicles.



ISO surface

(maximum chipping size 8mm)

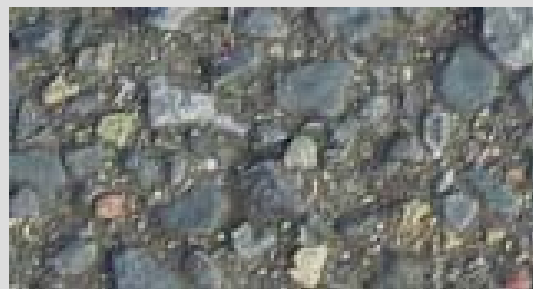

Dense asphalt concrete

(maximum chipping size 13mm)

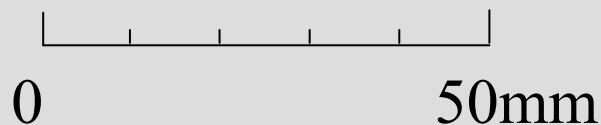

Test facilities



- Instruments

Minimum necessary instruments are;

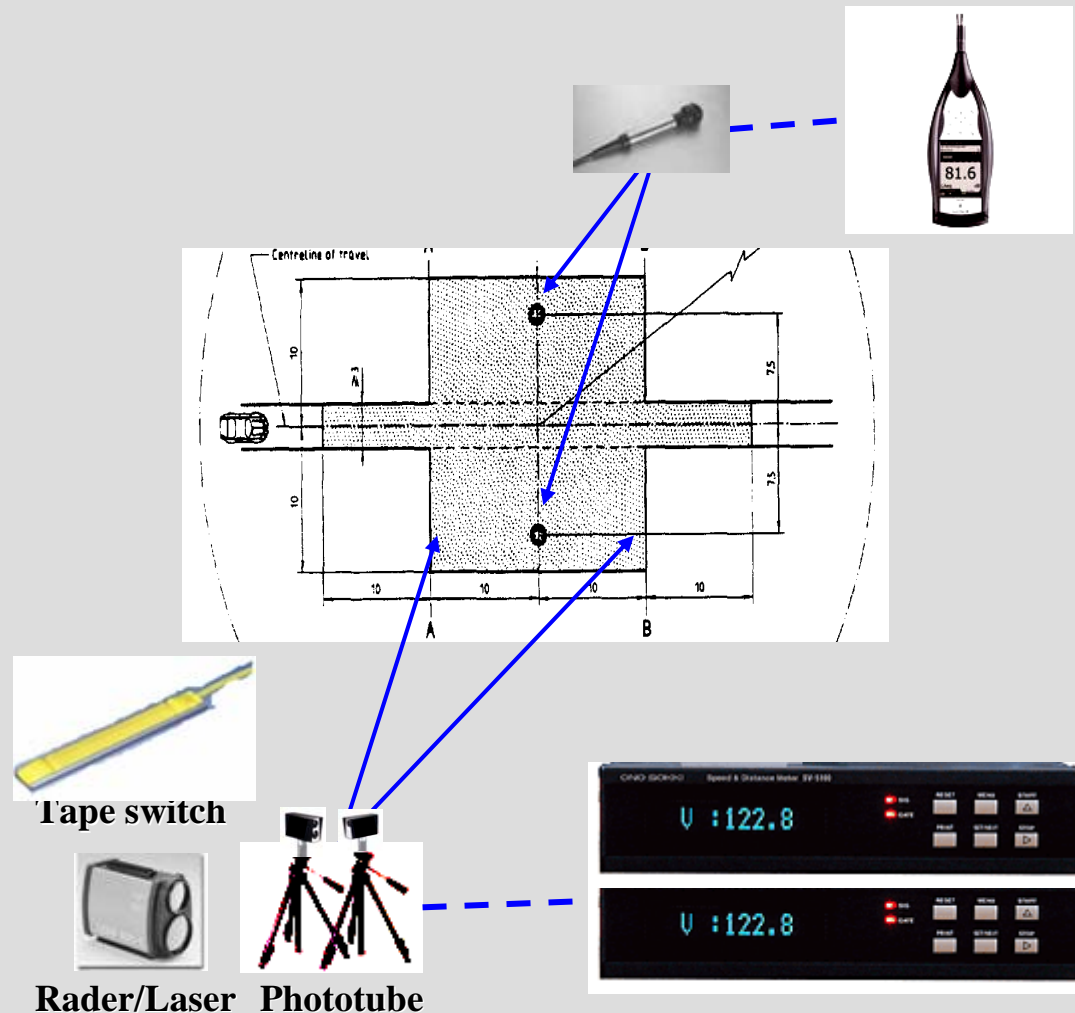

For sound measurement

Two sets of microphones and sound level meters are used for measurement of sound emitted from moving vehicle from right and left side

For vehicle speed measurement

Two sets of sensors and indicators are used for vehicle speed measurement at entrance and exit point of test area

Test facilities



- Sound measurement

Location of the instruments shall be as figure.

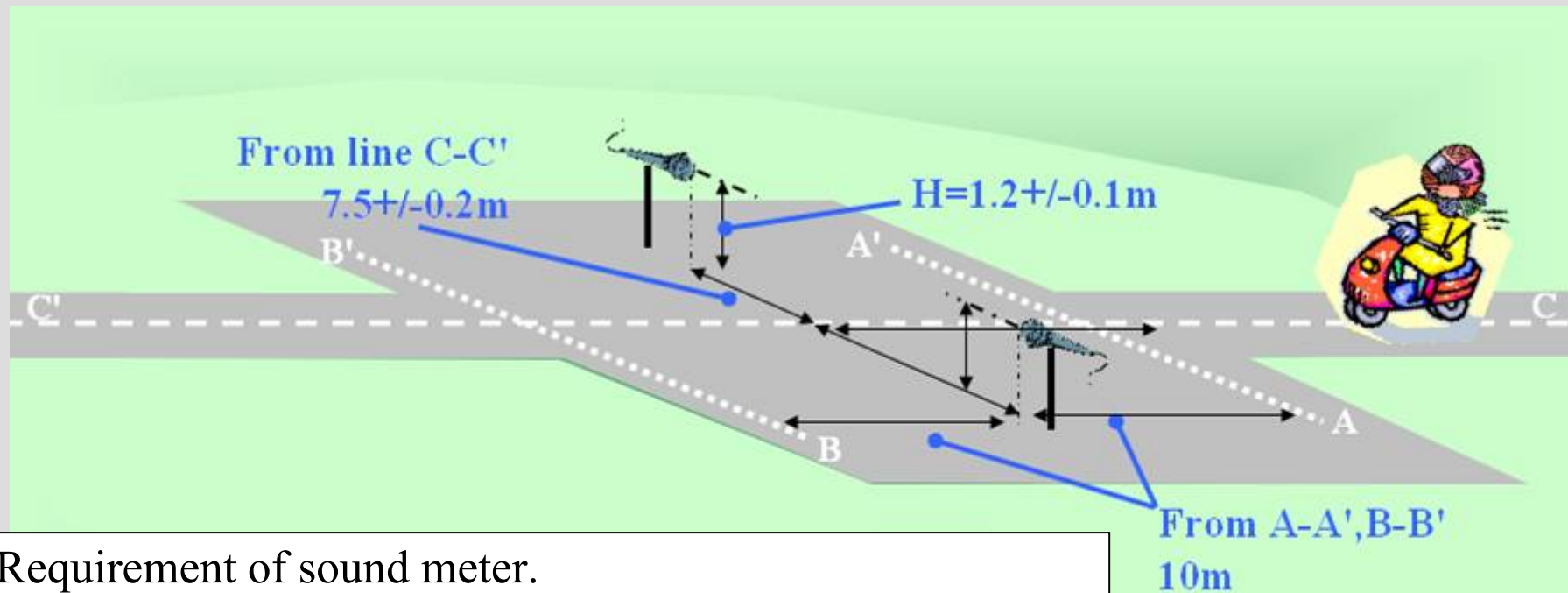

Requirement of sound meter.

- According to IEC standards.
- "FAST" response
- "A" weighting

Maximum sound level during acceleration shall be

Measured. (e.g. Using peak hold or using a level recorder)

Test facilities



- Vehicle speed measurement
Location of instruments is not mentioned in R41.
This figure shows location based on actual usage.

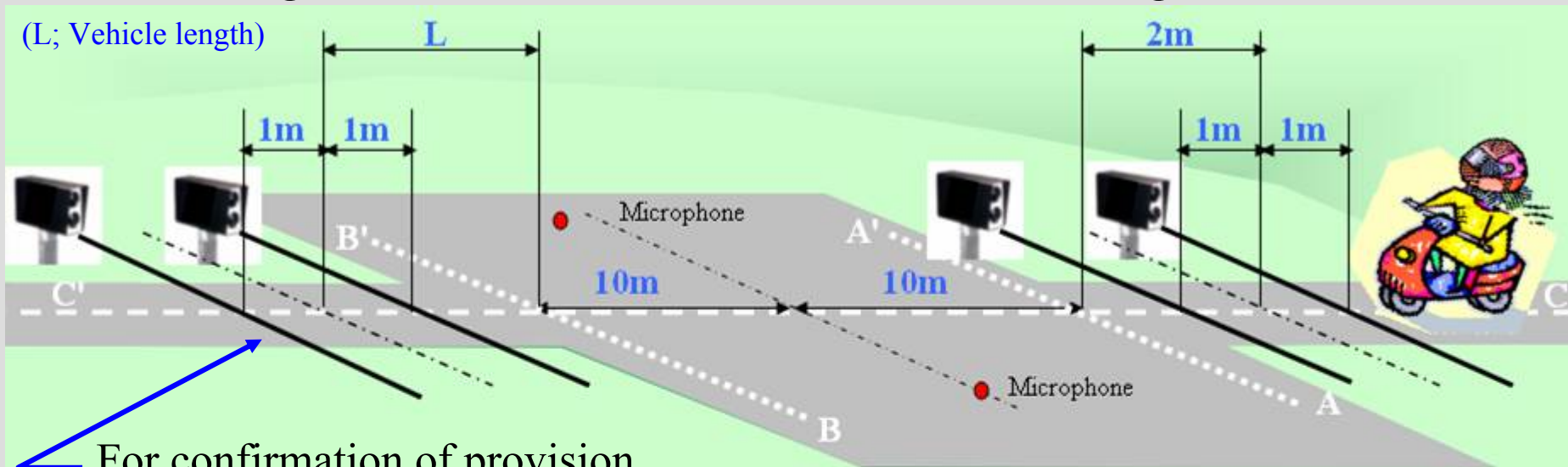

For confirmation of provision with regard to gear selection.

(Exit vehicle speed at sound measurement is not compulsory.)



Accuracy of vehicle speed measurement
: $\pm 3\%$

Overview of presentations

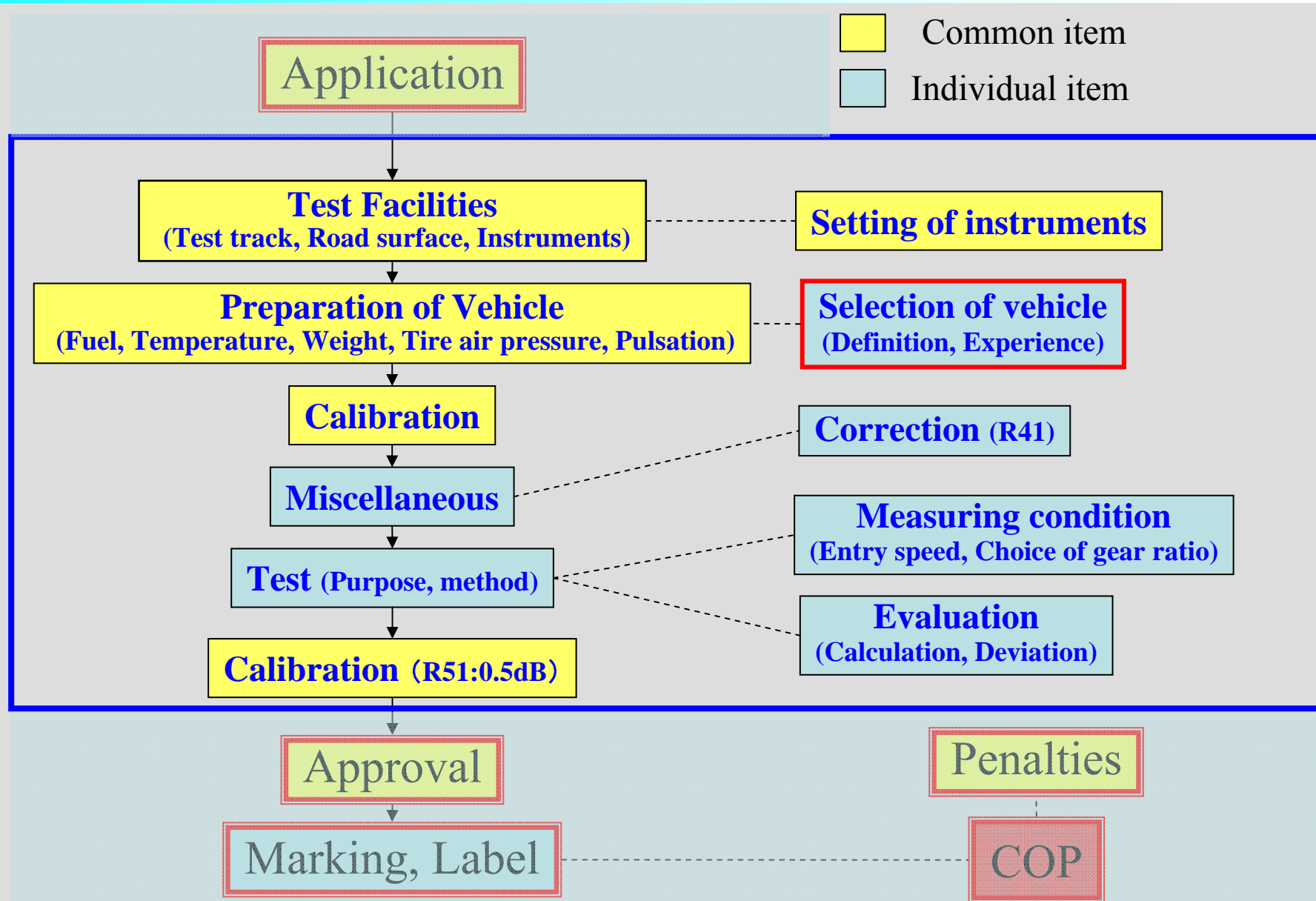

Selection of vehicle



- Definitions

1. **Type of motorcycle** as regards its sound level and exhaust system:

Type of engine

- Engine cycle (two-stroke or four-stroke)
- Reciprocating piston engine or rotary-piston engine
- number and capacity of cylinders
- number and type of carburetors or injection systems
- arrangement of valves
- Net maximum power and corresponding speed : (S)

Transmission systems

- Number and ratios of gears

Exhaust or silencing systems

- Number, type and arrangement of exhaust system (s)

2. Exhaust or silencing system(s)

- Factory or trade marks
- Materials of different
- Different shape or size
- Operating principles
- Different combinations.

3. Exhaust or silencing system (s) component

- Exhaust pipe work,
- Silencer proper
- Intake system (air filter) if any.

Selection of vehicle



Item	Contents	Variation to be tested
Engine	Type (See definition)	Each type
Transmission	Number and ratios of gears	
Exhaust or Silencing	Number, type and arrangement	
Gear ratio	Transmission Gear ratio, reduction gear ratio and tire diameter	Lowest (Selection of the worst case)
Vehicle mass	Curb mass	
Other part	Not related with noise (i.e. Brakes, Lamps, Name of tire etc.)	No need to be considered for vehicle selection

Selection of vehicle



New type approval

T: Tested
O: Omitted

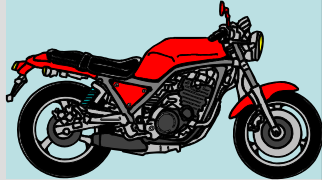
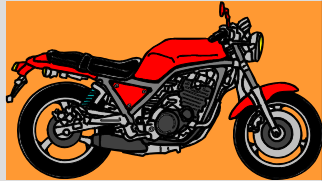
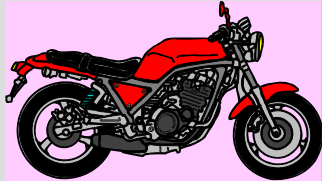
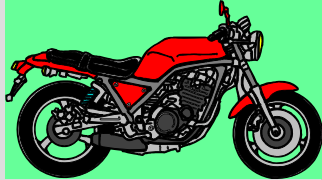
Vehicle type	Specification	
A 	Carburetor 5 M/T 190kg	T
B 	Fuel injection 6 M/T 195kg	T
C 	Fuel injection 6 M/T ABS 200kg	O
D 	Same as type B With different Manufacture's tire.	N/A

Extension type approval

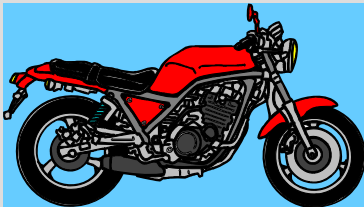
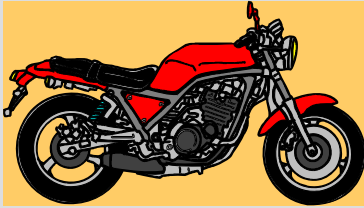
Vehicle type	Specification	
A' 	Carburetor 5 M/T 190kg Modification of Brake system	N/A
B' 	Fuel injection 6 M/T 192kg Modification of lighting devices	T

Overview of presentations

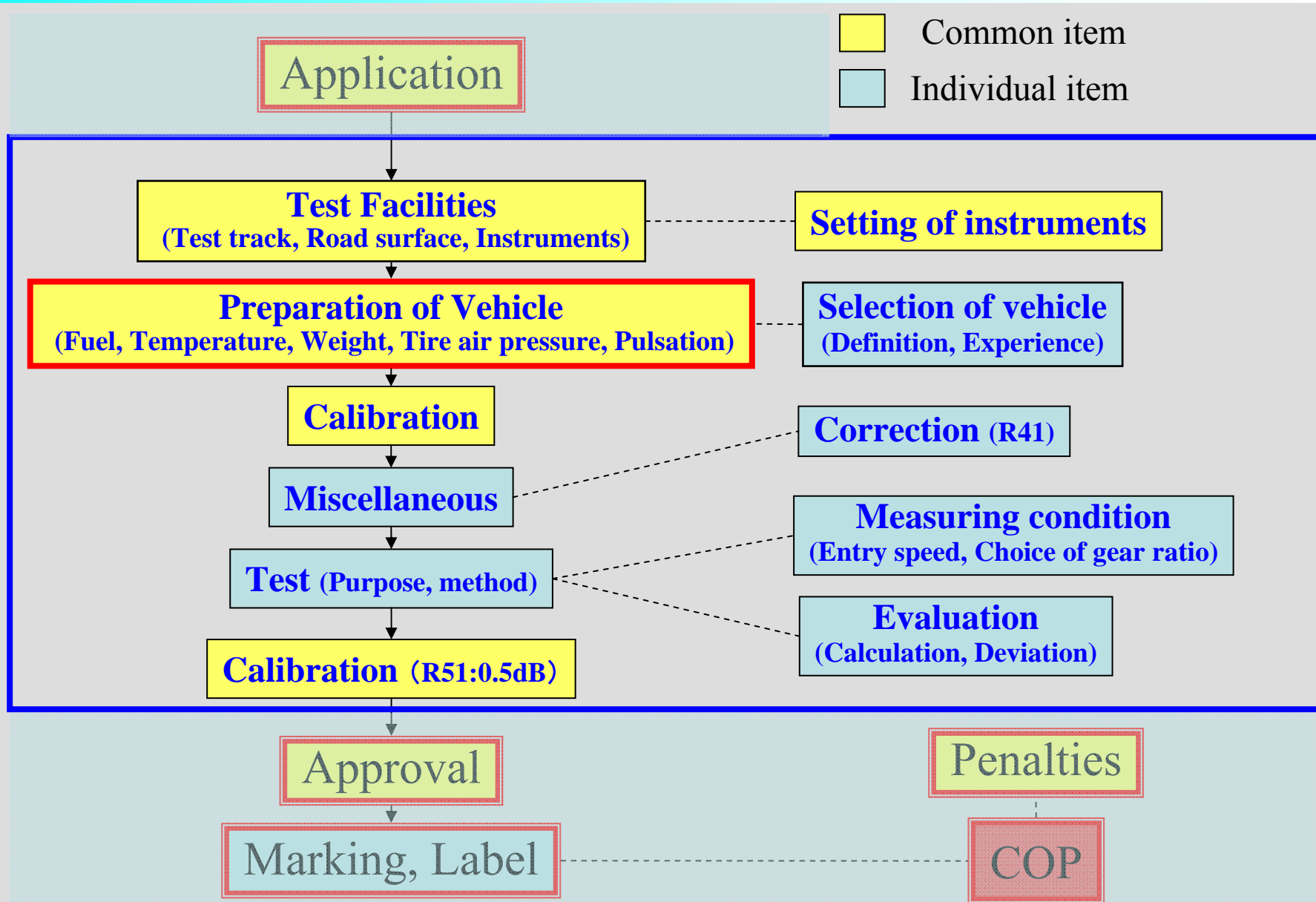

Preparation of vehicle



Motorcycle shall be in **running order**, including

- Coolant
- Oils
- Fuel
- Tool
- Spare wheel
- a Rider

Motorcycle engine shall be brought to the **normal operating temperature**.

Fans with an automatic actuating mechanism shall not be interfered with the sound measurements.

More than one driven wheel, only the drive provided for normal road operation may be used.

Sidecar must be removed.

Preparation of vehicle



Motorcycle equip **exhaust silencer with fibrous absorbent material**.
Before the system is tested in accordance with Annex 3, it must be put into a normal state for road use by **one of the following condition methods**:

- **CONDITIONING BY CONTINUOUS ROAD OPERATION**
4000 ~ 8000km running
- **CONDITIONING ON A TEST BENCH**
6 ~ 12 cycles *Conditioning cycle ; 2.5hours, consisted from 6 phases
- **CONDITIONING BY PULSATION**
Simulate normal state for road use increasing and release exhaust back pressure for 2500 times.

To simulate damage of fibrous absorbent material in actual usage on road.

Preparation of vehicle



•CONDITIONING BY PULSATION

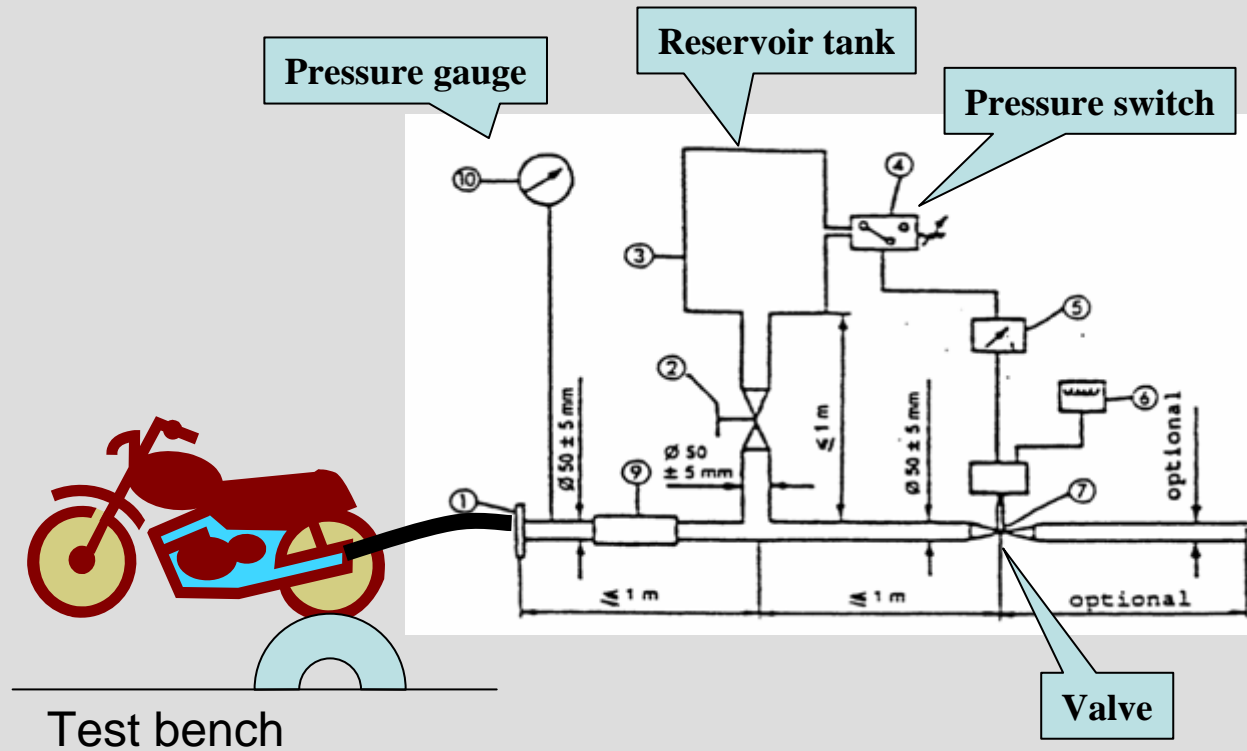

Exhaust outlet of the vehicle set on the test bench shall be connected to the inlet of test equipment without any leakage.

Preparation of vehicle



•CONDITIONING BY PULSATION

Vehicle set on the test bench should be operated under following engine speed and Engine load entire conditioning.

Engine speed must be
75 % of S(*).

The power indicated by the dynamometer must be 50 per cent of the full-throttle power measured at 75% of S.

(*)S ; The engine speed at which the engine develops maximum power

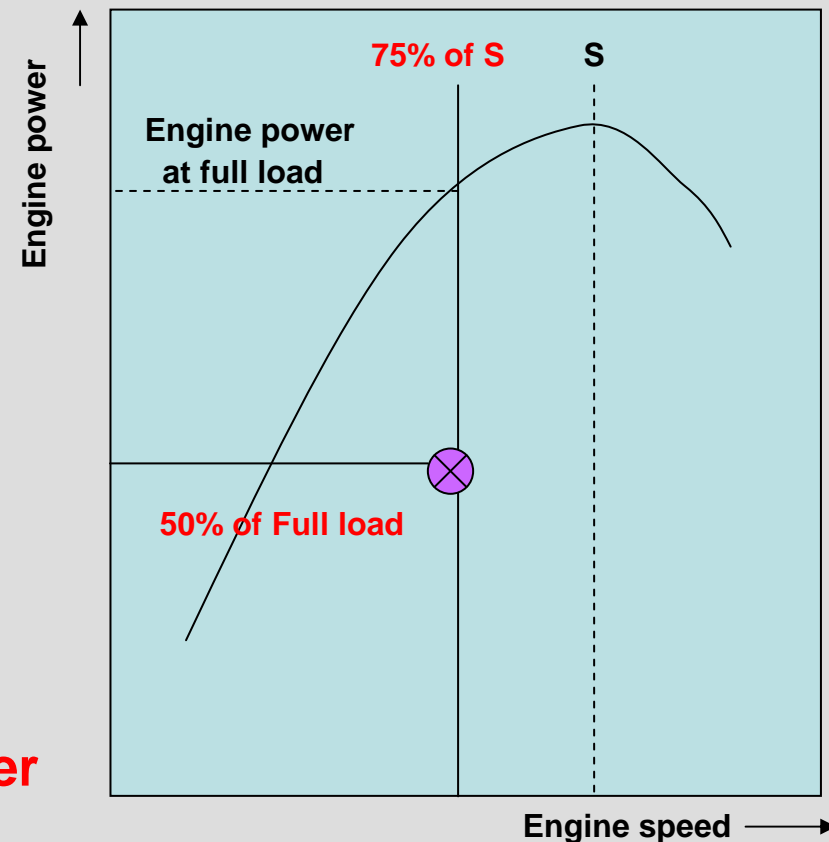

Preparation of vehicle



•CONDITIONING BY PULSATION

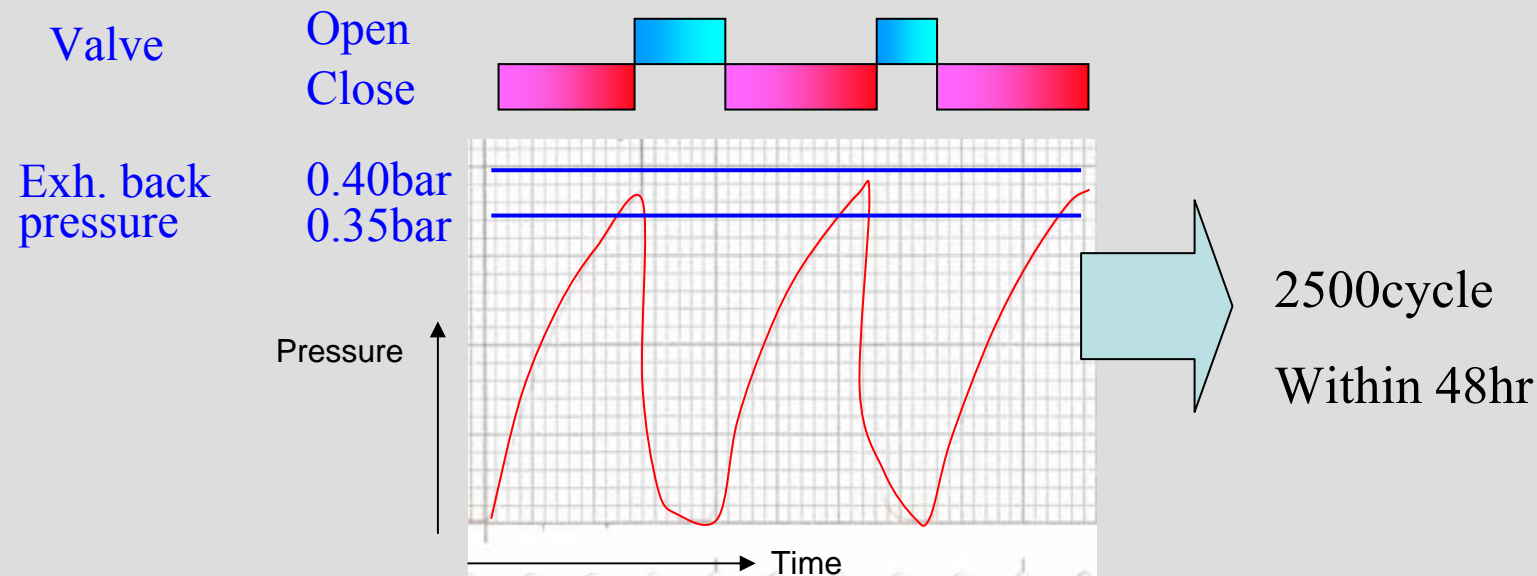

Back pressure should reach to **0.35 ~ 0.40 bar** (or 90% of maximum (100%=Engine stop)) with closing and opening the valve.

This cycle should be repeated **2500 times**. All of the conditioning cycle shall finish within **48 hours**.

Overview of presentations

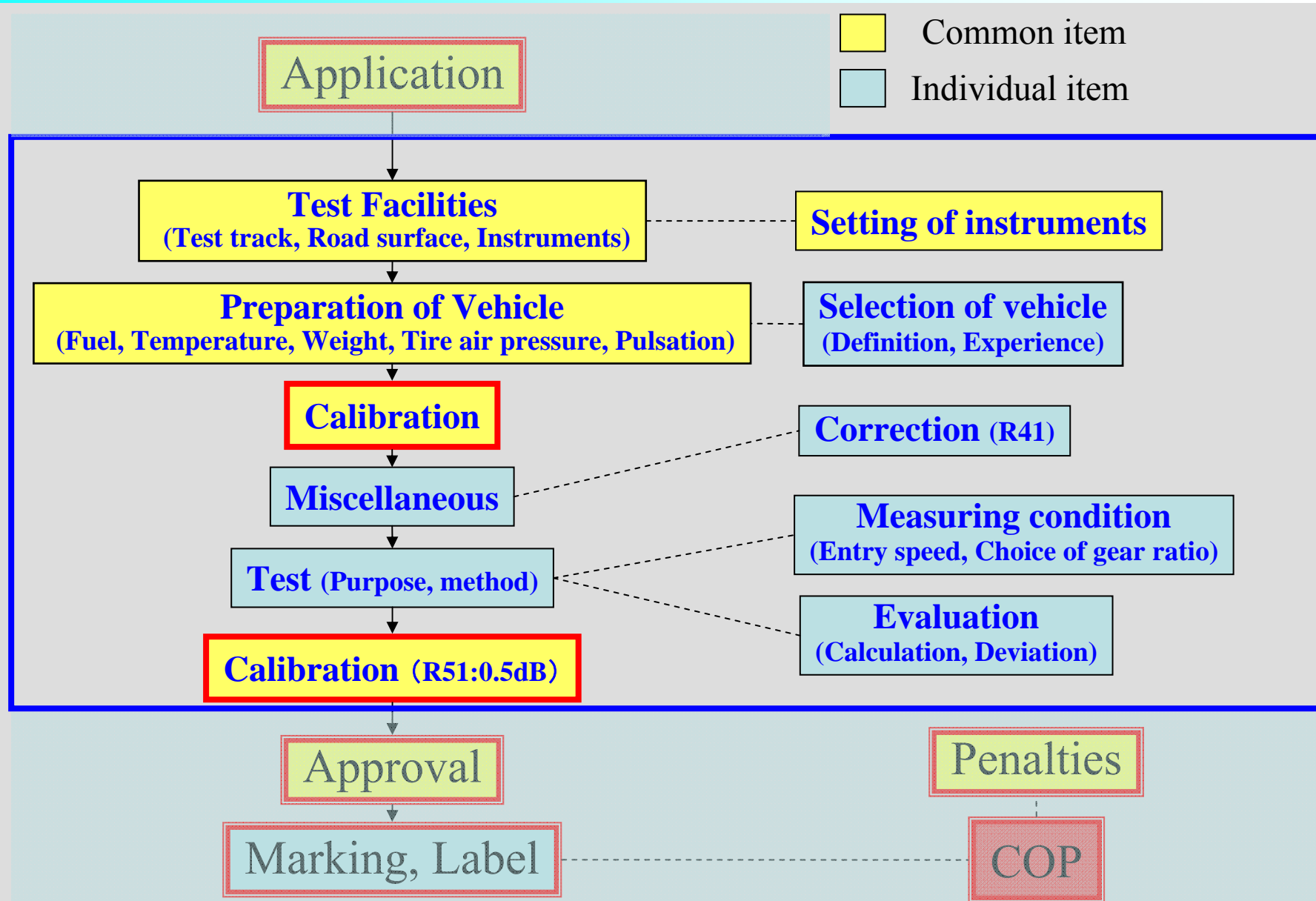

Calibration



- At the **beginning and end of each series of measurements** the sound level meter shall be calibrated in accordance with the manufacturer's instructions, using an appropriate sound source (e.g. **piston phone**).

Overview of presentations

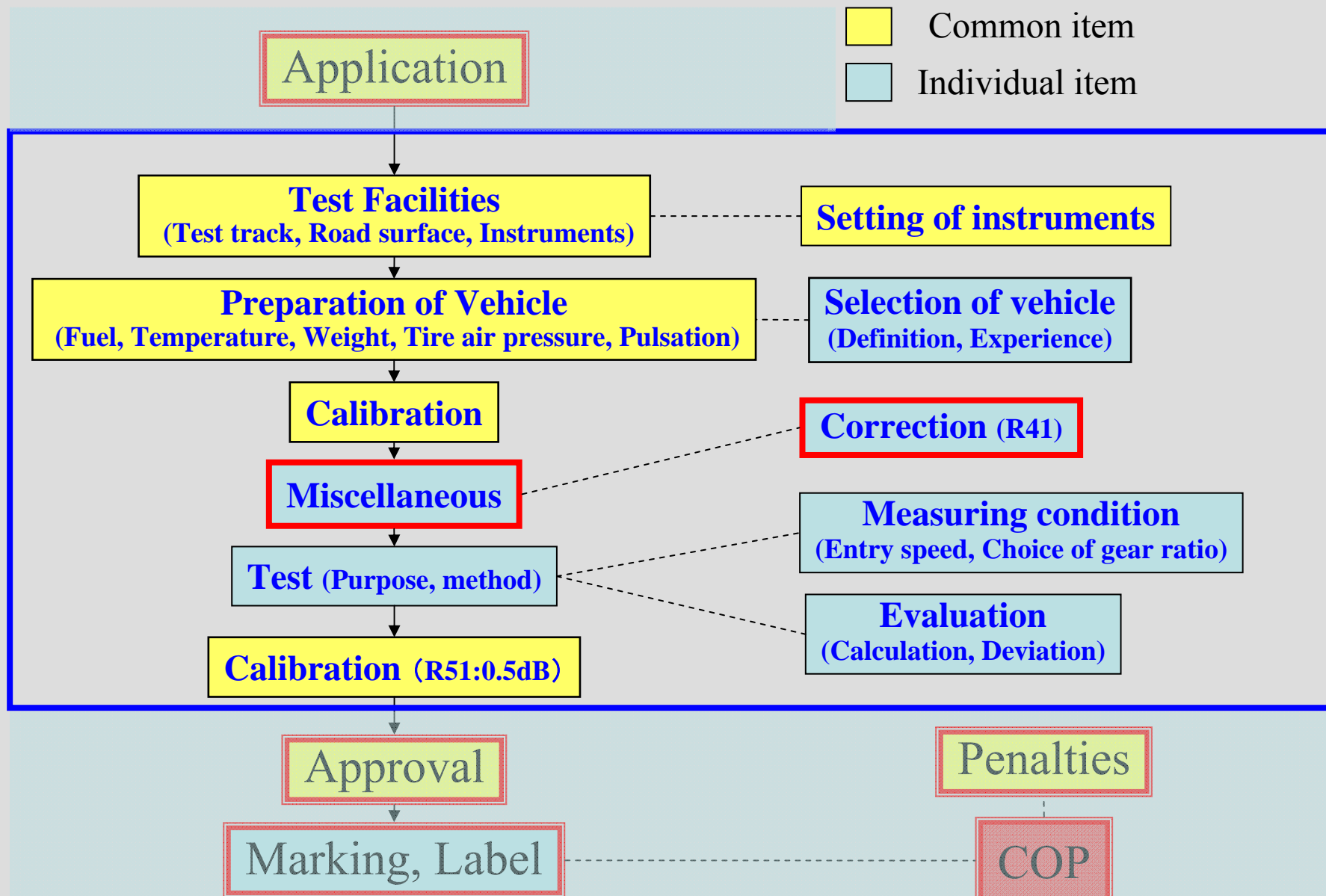

Miscellaneous



Measurements shall not be made in poor atmospheric conditions. It shall be ensured that the results are not affected by gusts of wind.

Ambient noise shall be **at least 10 dB(A) below the sound level** produced by the motorcycle.

If the **difference between the ambient Noise and the measured noise is Between 10 and 16 dB(A),**

in order to calculate the test results the appropriate correction shall be subtracted from the readings on the sound-level meter, as in the following graph:

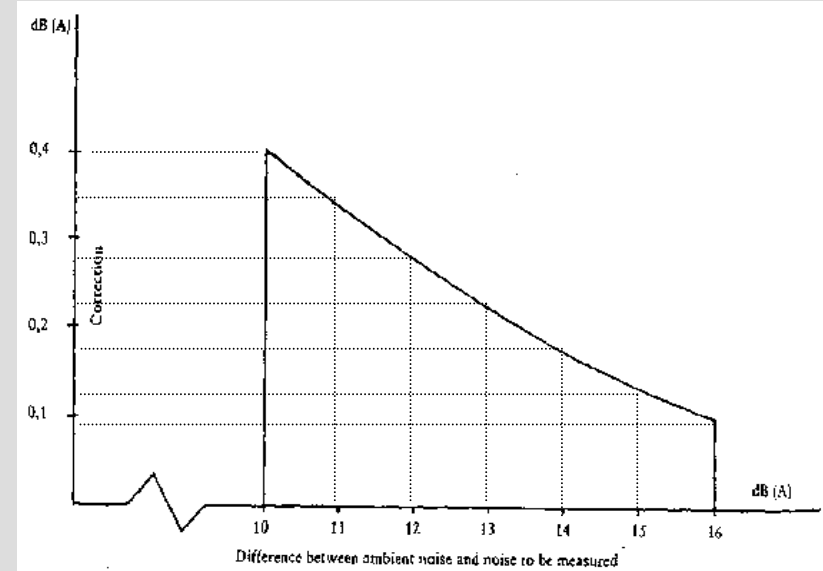

Overview of presentations

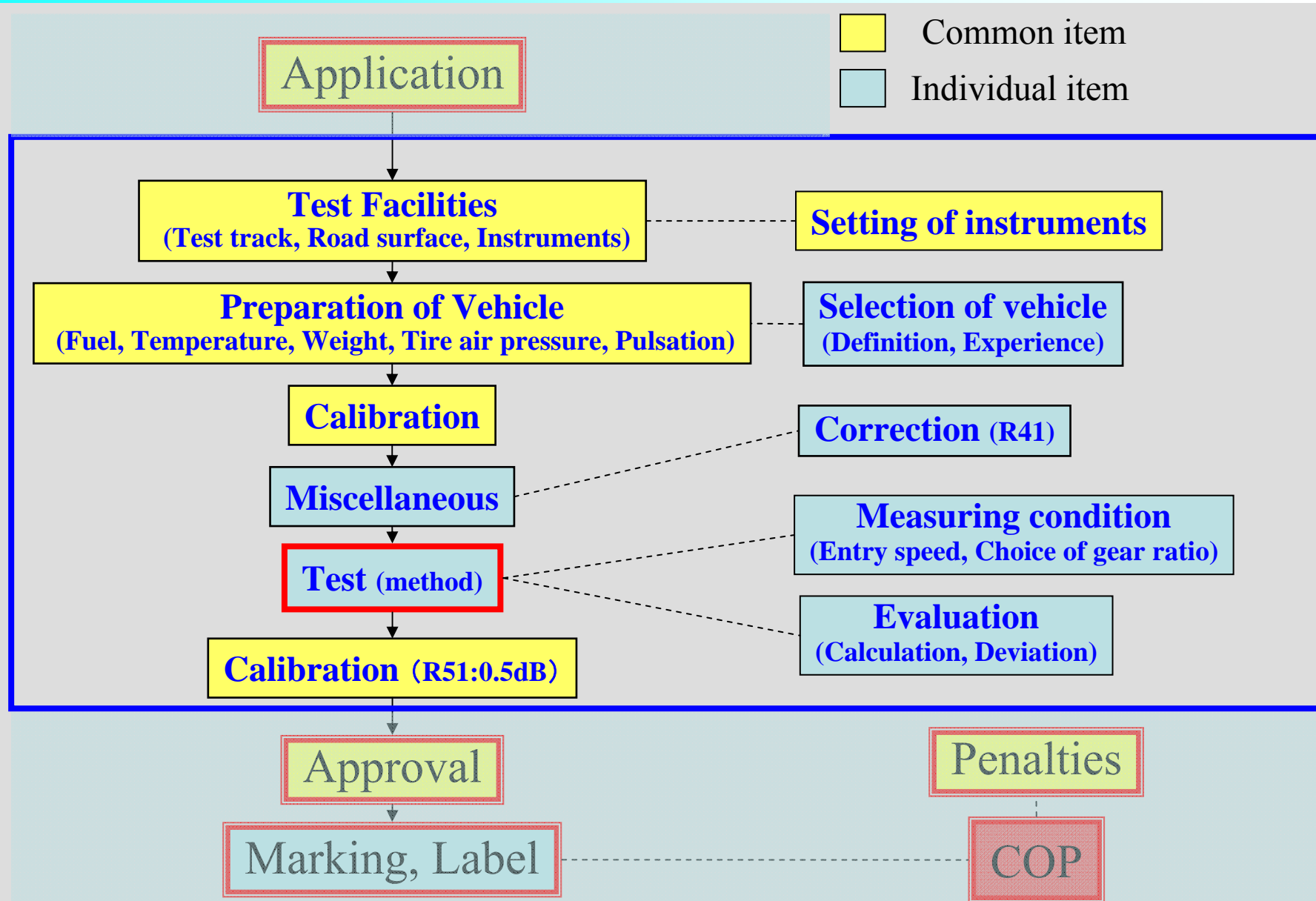

Test

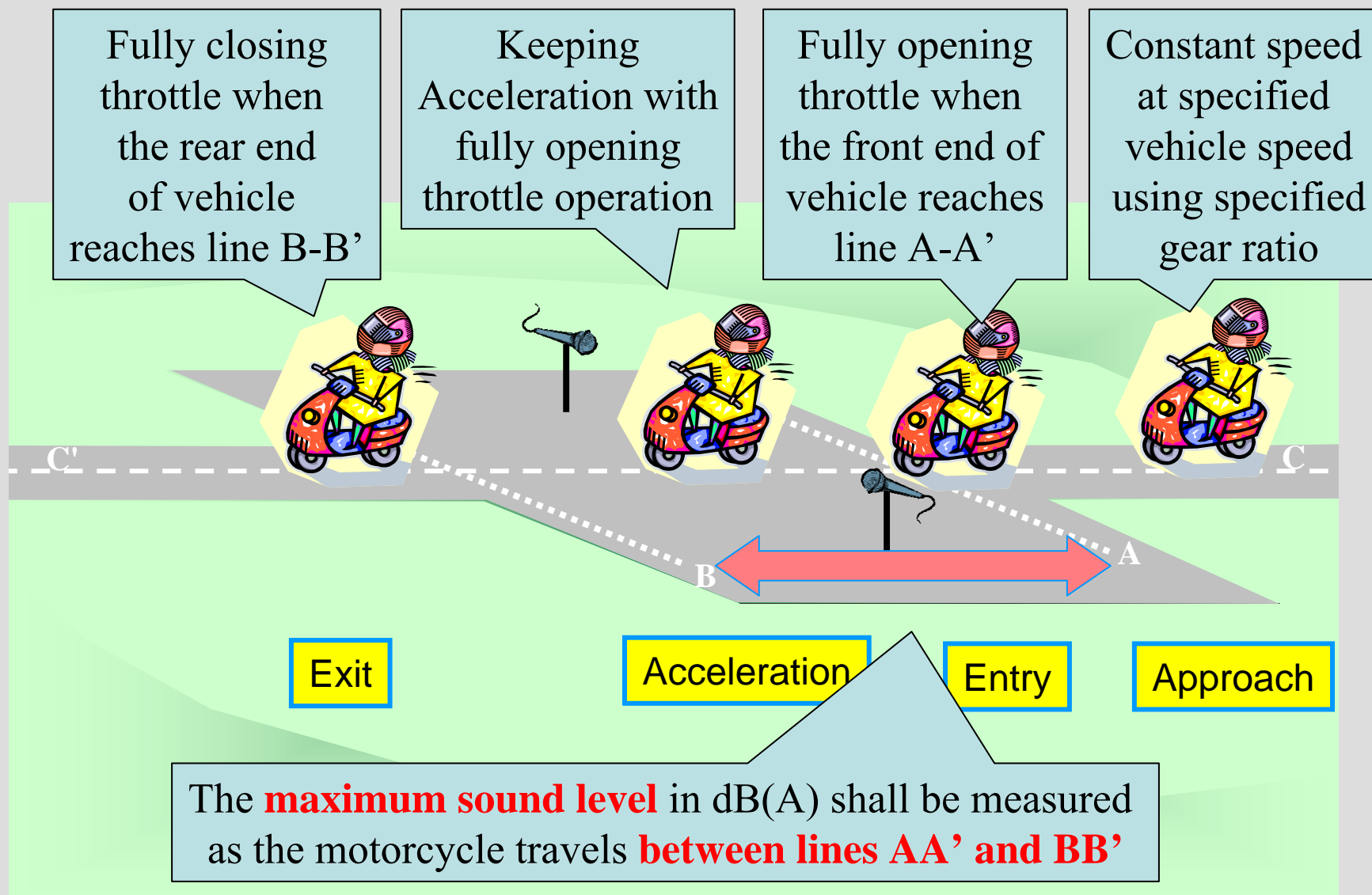

Overview of presentations

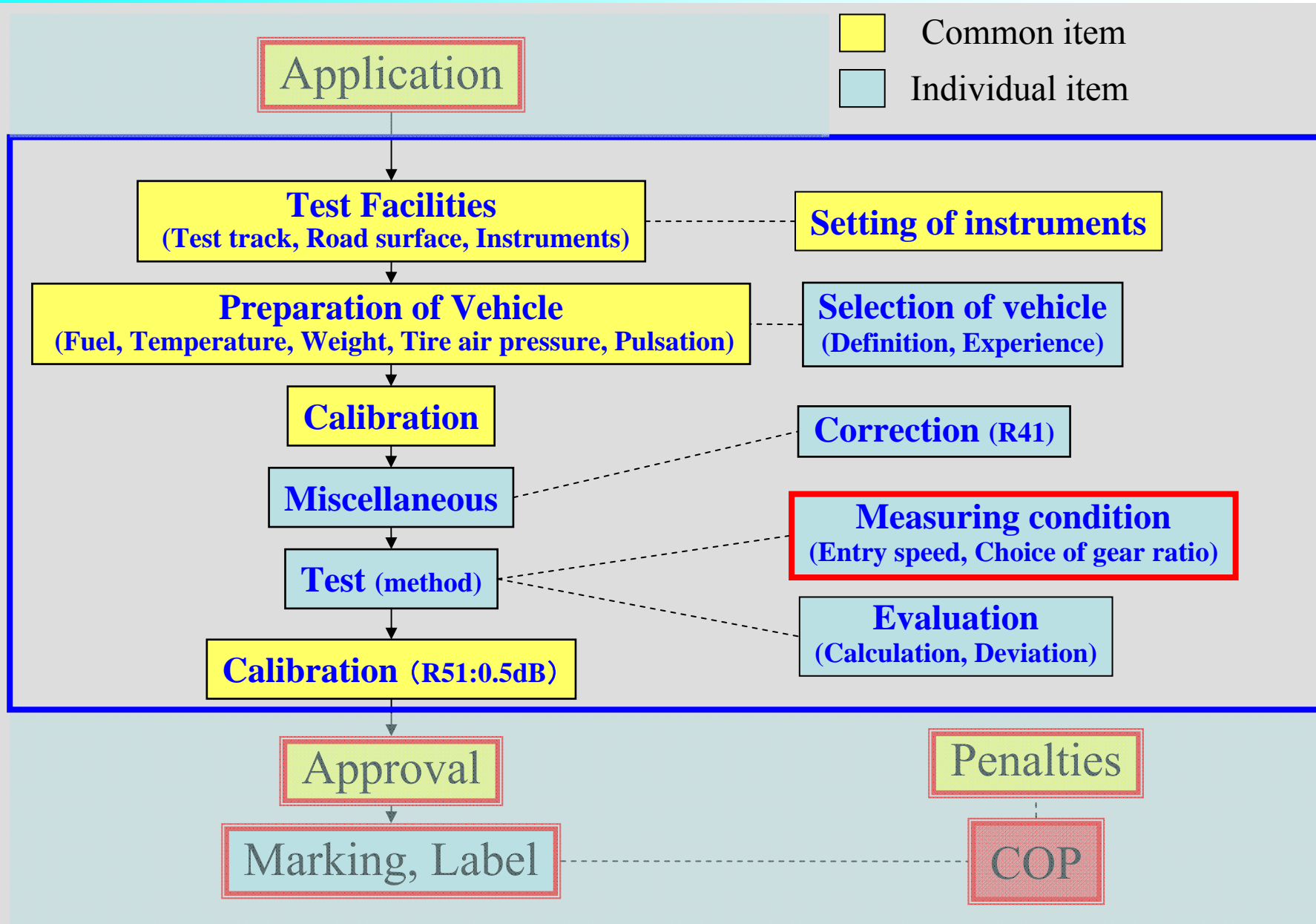

Measuring conditions for manually operated transmission



• Approach speed

(i) **50 km/h**

or

(ii) speed corresponding to
an engine speed equal to
75 % of S

The **lower** of these speeds shall
be selected.

• Choice of gear ratio

Engine Cylinder capacity	Total number of gear ratio	
	4 or less	5 or more
$\leq 175 \text{ cm}^3$	2 nd	3 rd
$175 \text{ cm}^3 <$		2 nd and 3 rd The result used must be the average of the two tests.

If, during the test carried out **in 2nd gear, the engine speed at the end of the test track exceeds 100% of S, the test must be carried out in 3rd gear** and the sound level measured shall be the only one recorded as the test result.

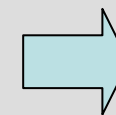

This is called as
“Over-run”.

How to check Over-run

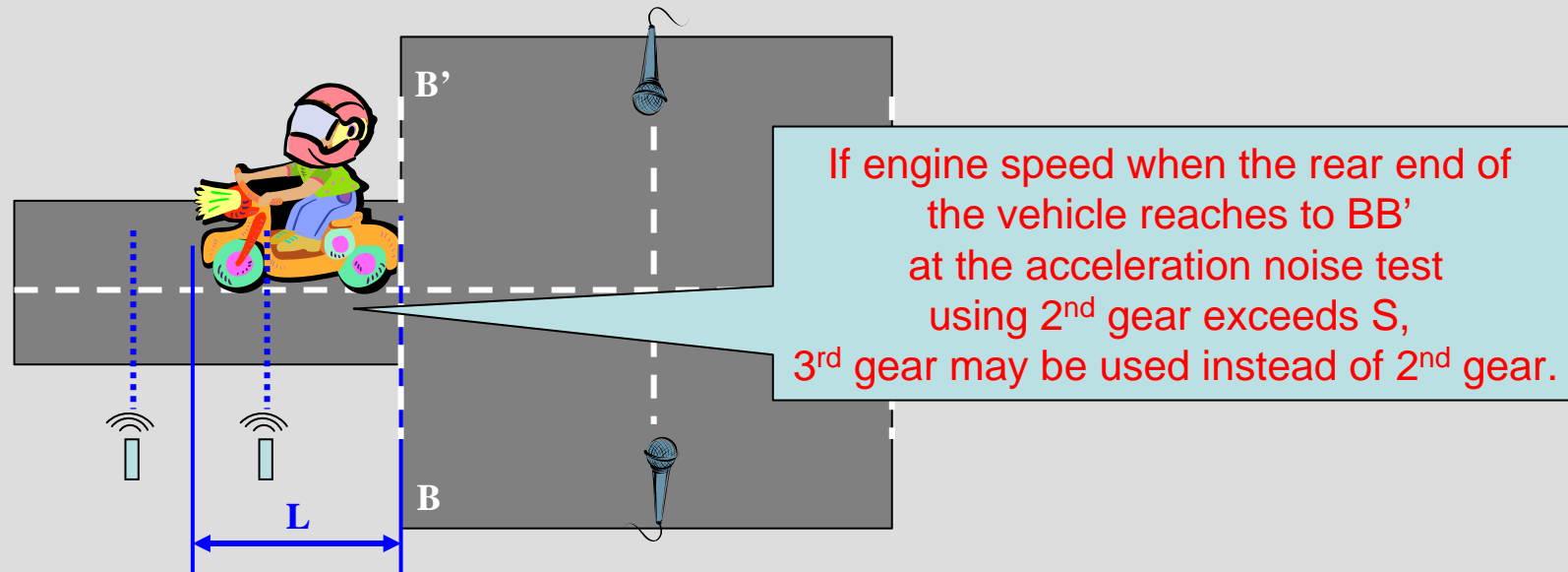

Engine speed shall be checked, If engine speed measurement is not available, the following equation should be used.

$$\text{over-run vehicle speed} = \frac{(\text{rated engine speed (rpm)}) \times \pi \times (\text{tire diameter})}{60 \times (\text{gear ratio}) \times (\text{Reduction ratio})}$$

Vehicle speed at BB'+L > over-run vehicle speed

Measuring conditions for automatic transmission (w/o selector)



- Approach speed

30, 40 km/h

and

50 km/h or 75 % of S

(if that speed is lower)

The condition giving the highest sound level is chosen.

- Choice of gear ratio

N/A

Measuring conditions for automatic transmission (with selector)



- Approach speed
less than 50 km/h, the engine speed equal to 75 % of S

or

- 50 km/h, the engine speed less than 75 % of S

If, in the test at a steady speed of 50 km/h, the gears change down to first, the approach speed may be increased to a maximum of 60 km/h to avoid the change down.

- Choice of gear ratio

If the motorcycle is equipped with a manual selector with X forward drive positions,

the test shall be carried out with the selector in the highest position; the voluntary device for changing down (e.g. kick down) shall not be used.

If an automatic change down takes place after line AA', the test shall be begun again using the second highest position or the third highest position if necessary, in order to find the highest position of the selector at which the test can be performed without an automatic change down (without using the kick down).

Overview of presentations

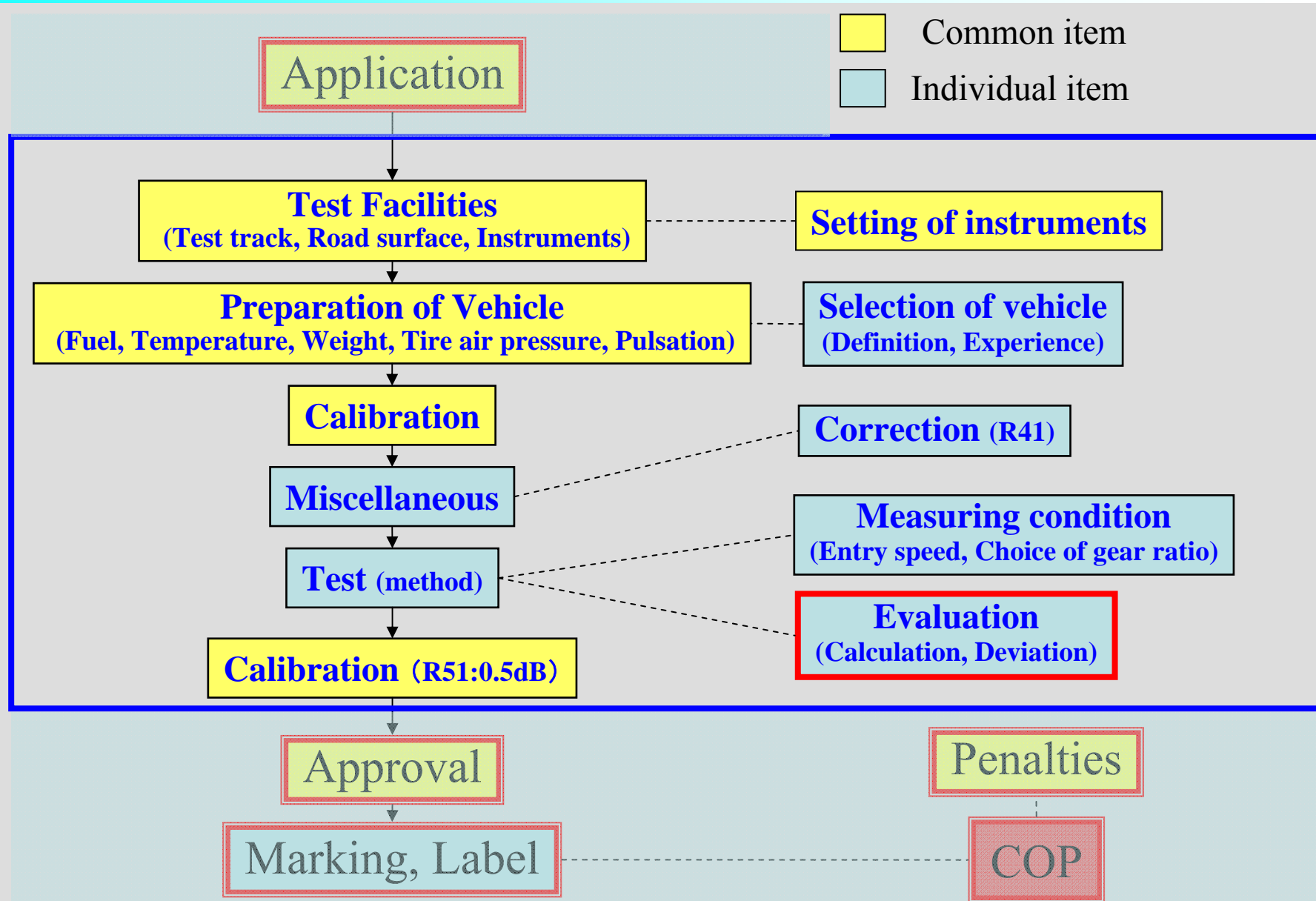

Nature and number of measurements

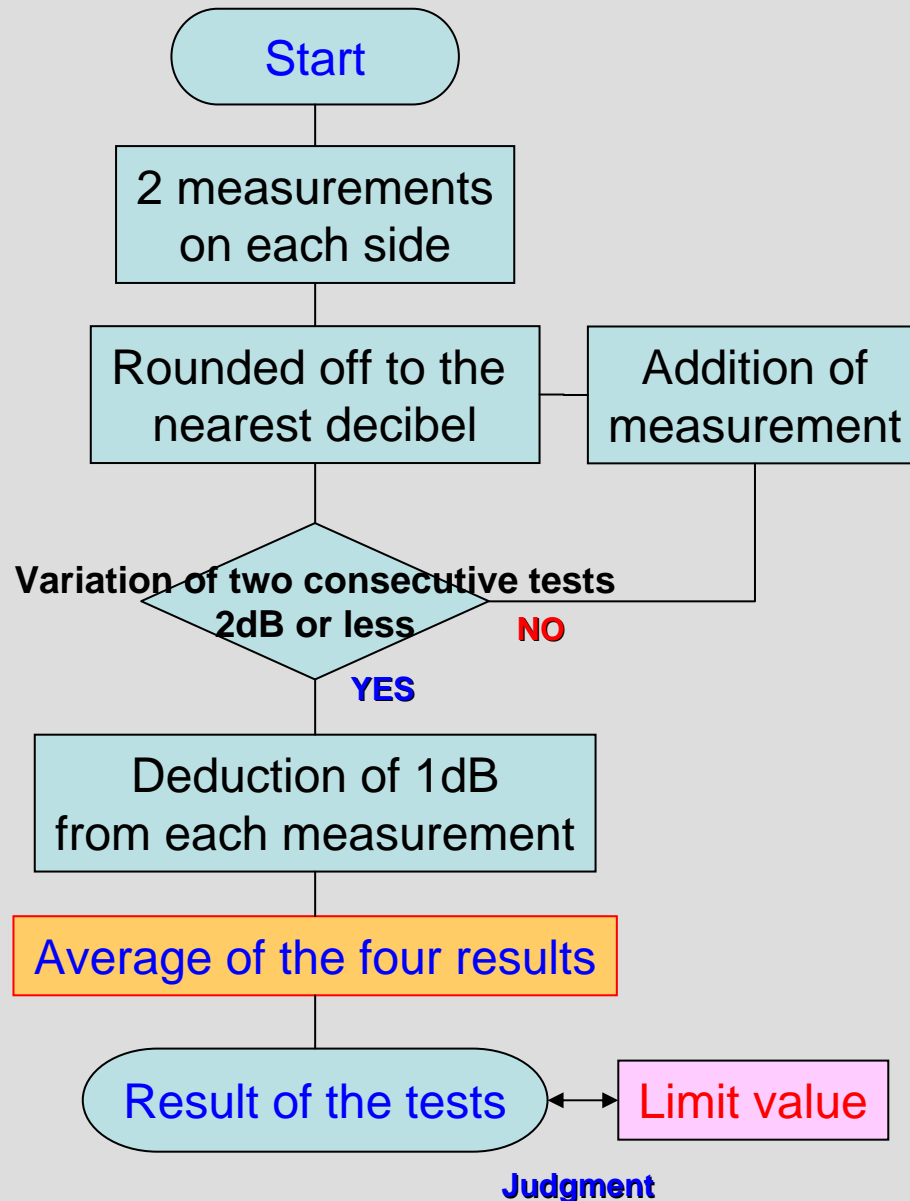

- At least **two measurements** shall be taken **on each side** of the motorcycle.

- Rounding

Readings shall be **rounded off to the nearest decibel.**

- Variation of value

variation in **two consecutive tests on the same side is less than or equal to 2 dB(A)**

- To take account of inaccuracies

The result of each measurement shall be **deducted 1 dB(A) from the rounded value.**

- If the **average of the four results** of the measurements will constitute the result of the test.

Test results (Example, $\leq 175\text{cm}^3$, 5gears)

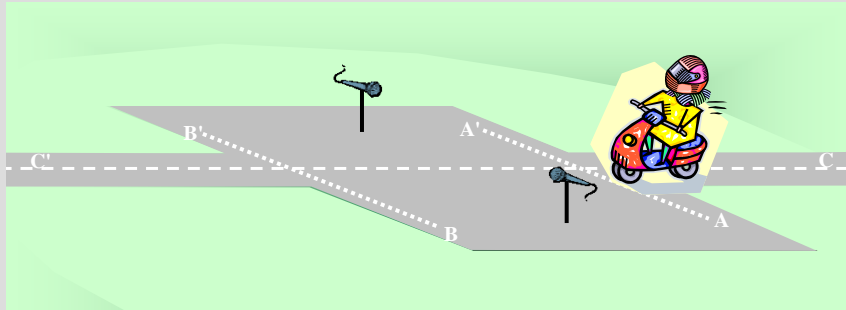

Making a Judgment of Over-run
 Corresponding vehicle speed to S : 55.0km/h
 Measured vehicle speed at B-B' : 55.6km/h
3rd gear shall be used instead of 2nd



76.2	78.5	76.2	76.5
75.9	75.4	75.9	75.4

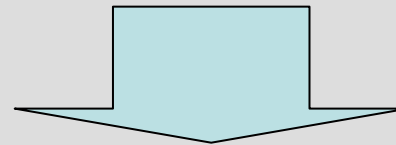

Measurement		1 st	2 nd	3 rd	4 th	Result	Limit
2 nd gear	R	N/A					80 Comply
	L						
3 rd gear	R	76	X 79	76	77	76	
	L	76	75	76	75		



Test procedures



R41 for Motorcycles

- ◆ *Acceleration noise*
- ◆ *Stationary noise*

Overview of presentations

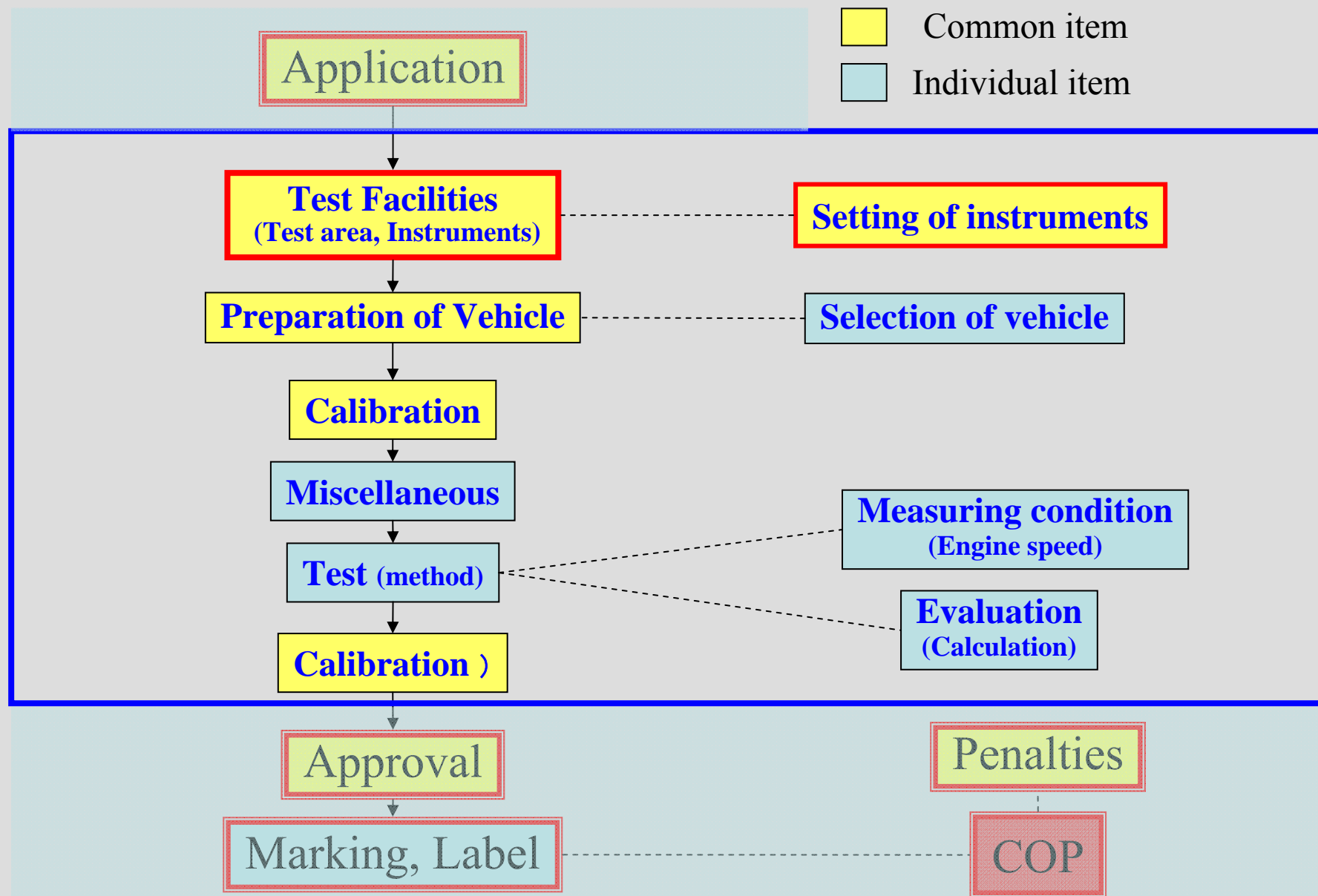

Test facility



- Test area

No significant acoustic disturbances may be used.

Flat surfaces covered with **concrete, asphalt** or some other hard material

Test site must be in the form of a rectangle whose sides are **at least 3 m from the outer edge of the motorcycle** (handlebars excluded). There shall be no significant obstacles, e.g. no persons other than the rider and the observer may stand within this rectangle.

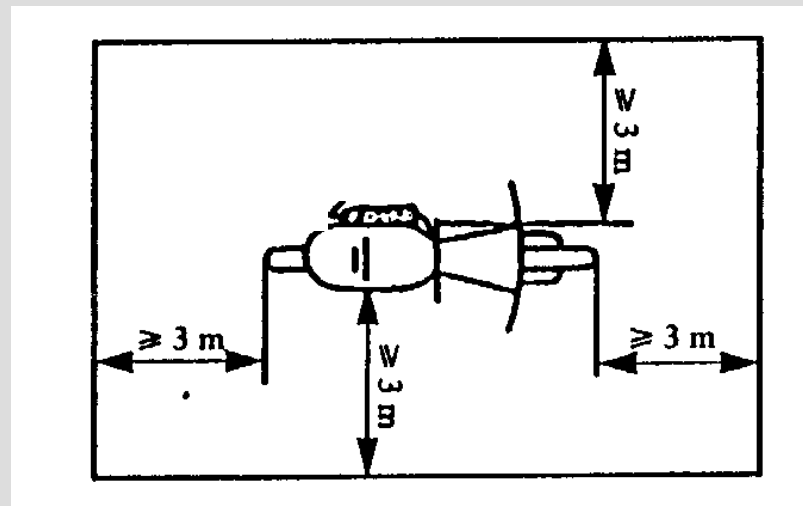

Test facilities



- Instruments

For sound measurement

A precision sound-level meter shall be used. (refer to IEC standard)

- “A” weighting
- “FAST” response
- Peak hold



For engine speed measurement

Engine tachometer

Accuracy +/-3%



Overview of presentations

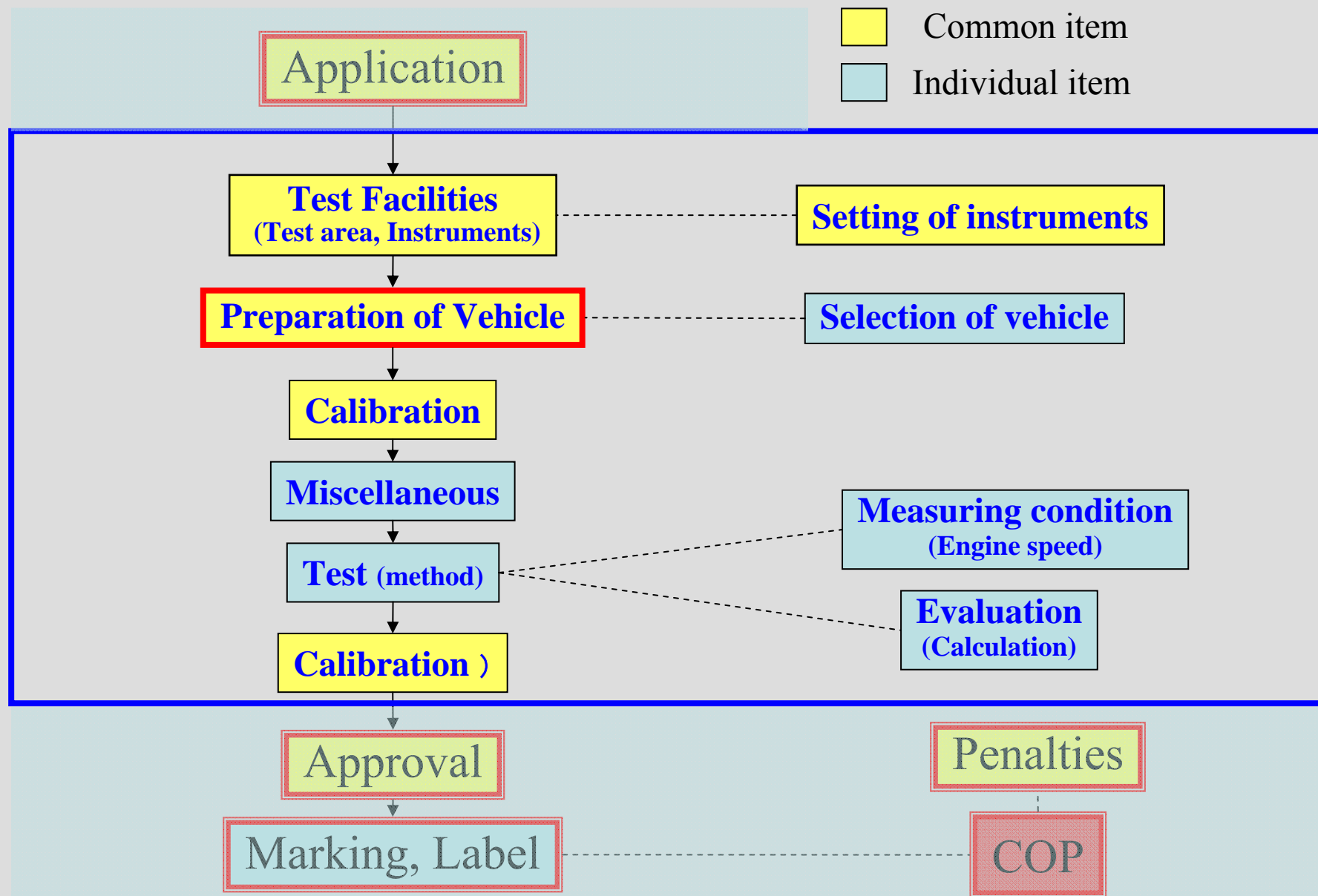

Vehicle preparation



- Condition of the motorcycle

The motorcycle engine shall be brought to the **normal operating temperature**.

Fans with an automatic actuating mechanism, this system shall not be interfered with during the sound measurements.

During the measurements the gearbox shall be in **neutral gear**.
If it is **impossible to disconnect the transmission**, the driving wheel of the motorcycle shall be allowed to rotate freely, **for example by placing the vehicle on its centre stand**.

Overview of presentations

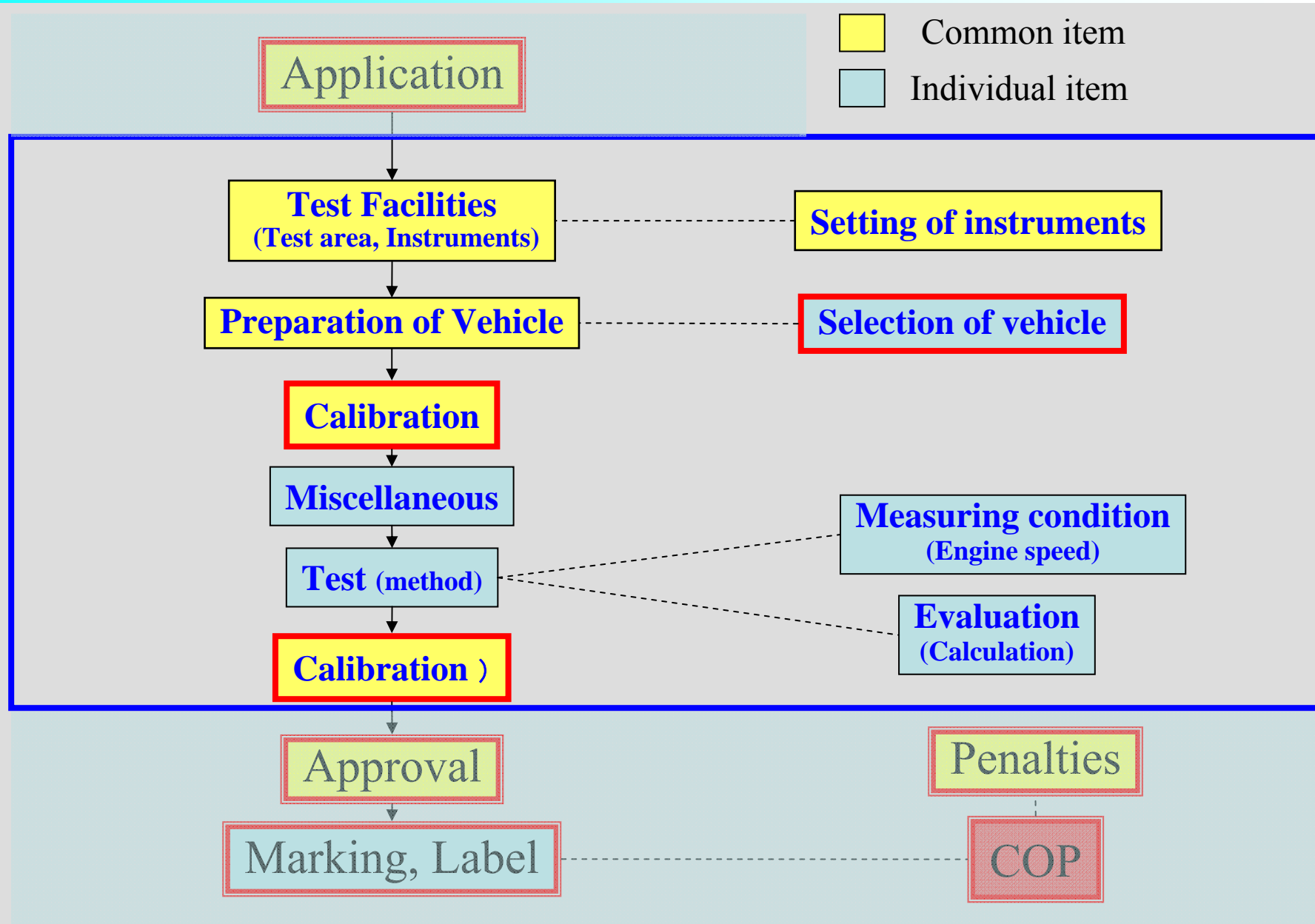

Selection of vehicle / Calibration



- Same as its for measurement of vehicle in motion.

Overview of presentations

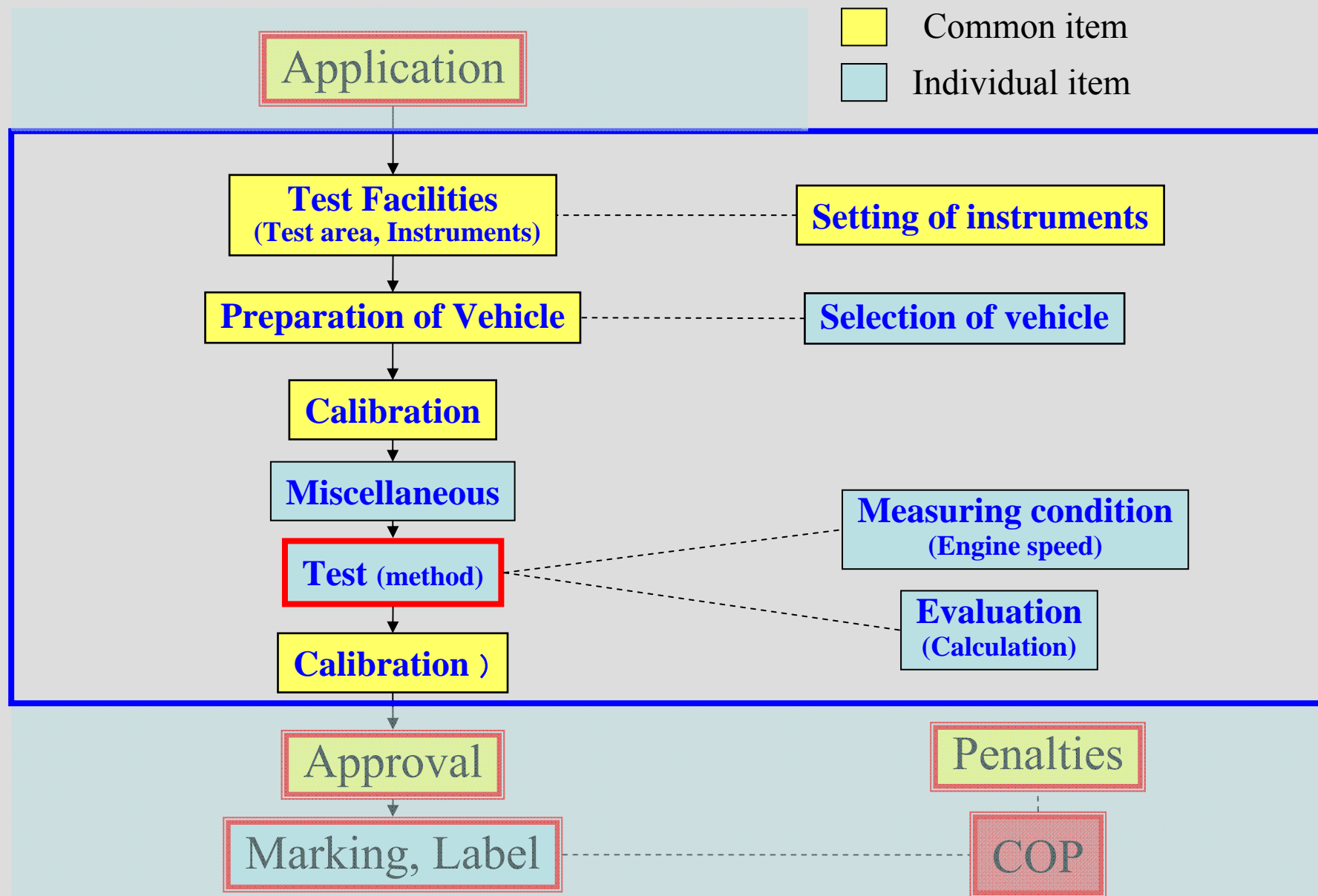

Operation



Operating conditions

The engine speed shall be held steady at one of the following values:

S is more than 5000 rpm $\frac{1}{2} * S$

S is not more than 5000 rpm $\frac{3}{4} * S$

When a constant engine speed is reached, the throttle shall be returned swiftly to the idle position.

Setting of microphone



Microphone setting

- Height
Same as exhaust outlet or 0.2m above ground, which is lower.
- Distance from exhaust outlet
0.5m from exhaust outlet.
- Angle to exhaust outlet
45 +/- 10° to the exhaust outlet.

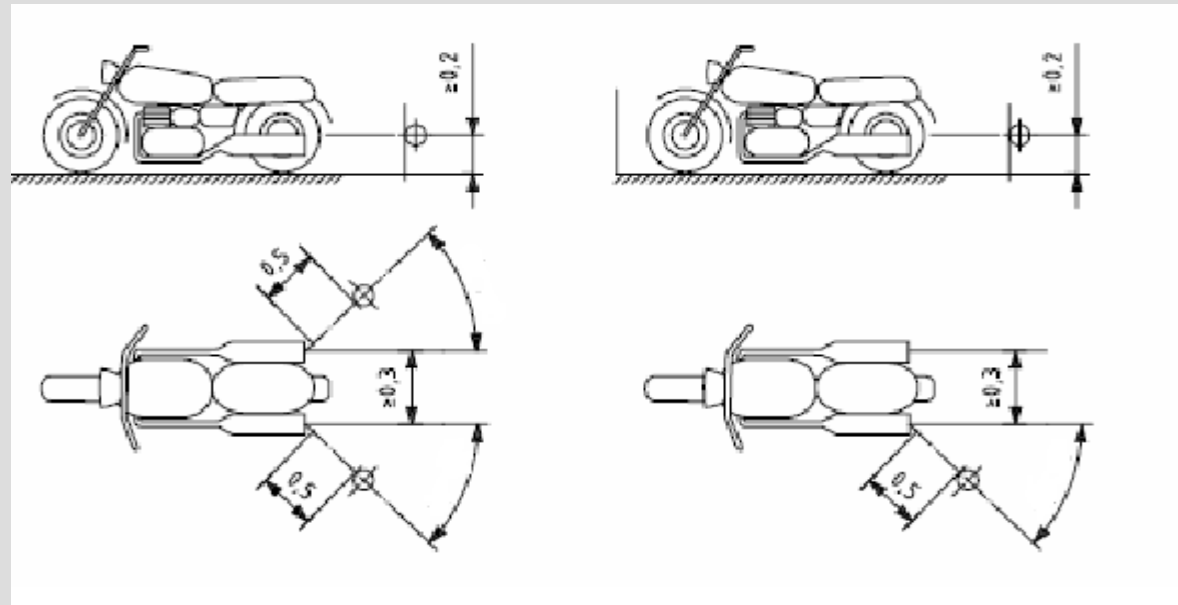

Setting of microphone



In case that the exhaust system has more than one outlet at centers **less than 0.3 m apart**.

The microphone shall be faced towards the outlet which is **nearest the motorcycle** (handlebars excluded) or towards the outlet which is **highest** above the surface of the track.

If the centers of the outlets are **more than 0.3 m apart**.

Separate measurements shall be taken for **each of them**.

The **highest** figure recorded being taken as the test value.

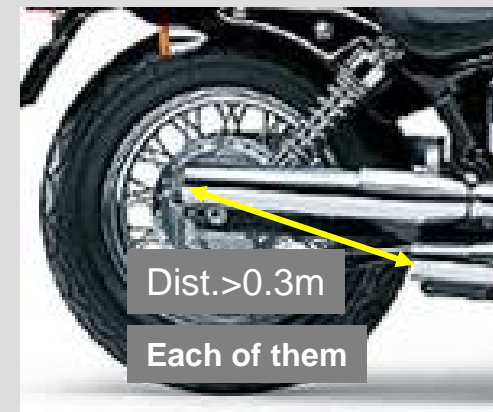

Overview of presentations

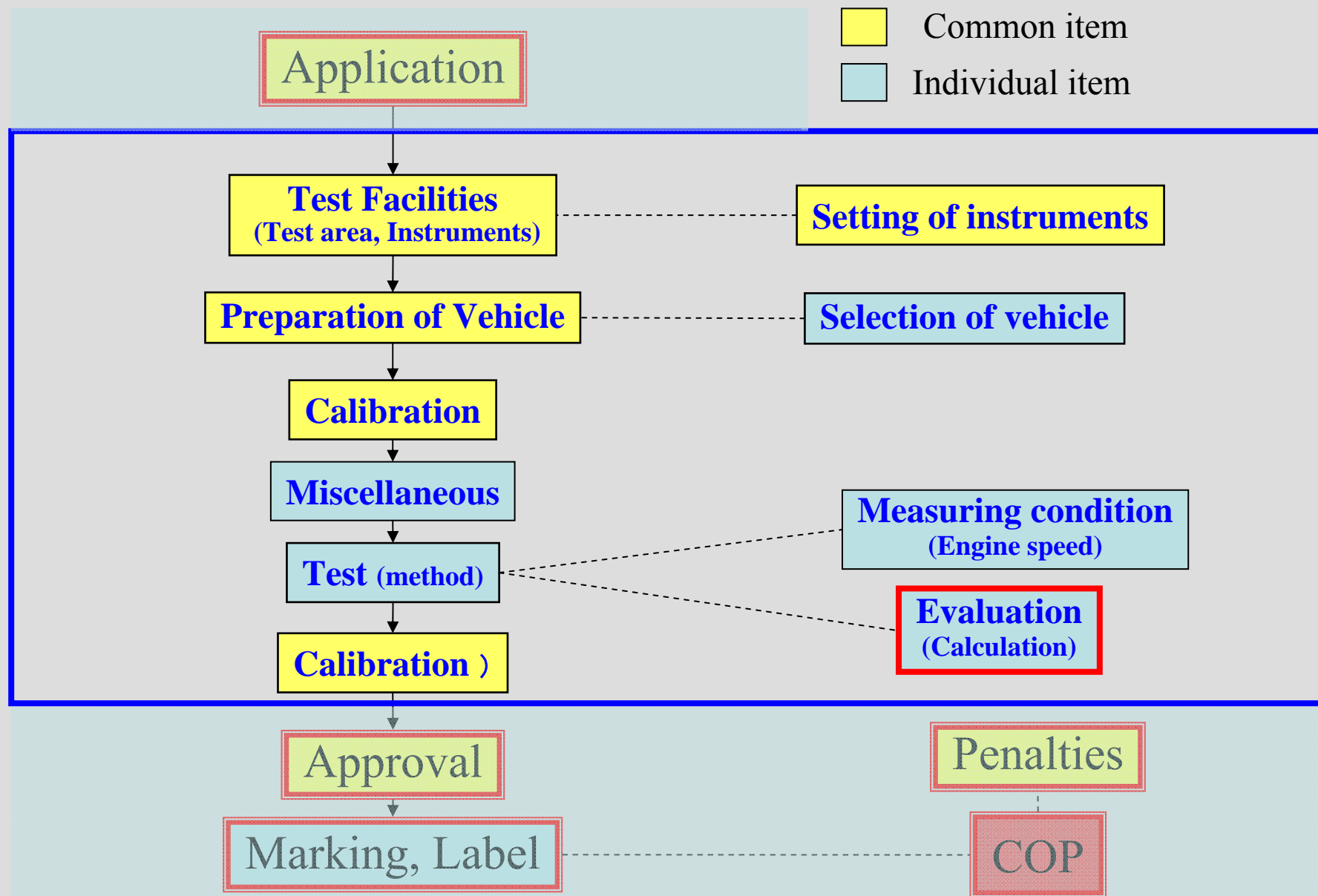

Sound value, Evaluation



The sound level shall be measured during an operating cycle consisting of a **brief period of constant engine speed and throughout the deceleration period**, the **maximum sound-level** meter reading being taken as the test value.

- Rounding

Values shall be **rounded off to the nearest decibel**
(Same as Acceleration noise test)

- Variation

Value shall not vary by **no more than 2 dB(A)**

- Number of measurement

Three consecutive tests will be carried out.

- Final value

The **highest value** of the three measurements.

- Judgment

There is no limit value due to reference value.

Sound value, Evaluation (Sample)



Spec. Max Power ; 50kW / 7000min⁻¹

Measuring condition ; 3500min⁻¹

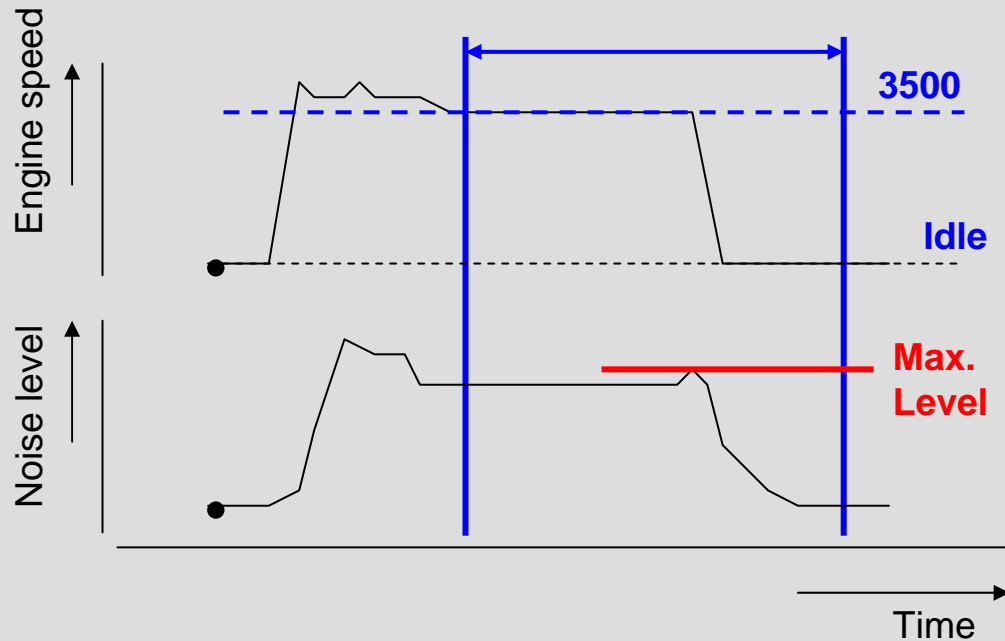
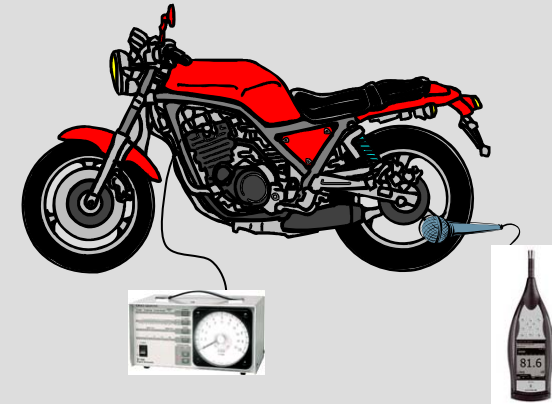

91.2 87.2 87.0 87.6

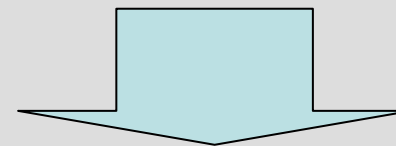

Measurement	1 st	2 nd	3 rd	4 th	Result	Limit
Noise level (dB(A))	91	87	87	88	88	No (Reference)

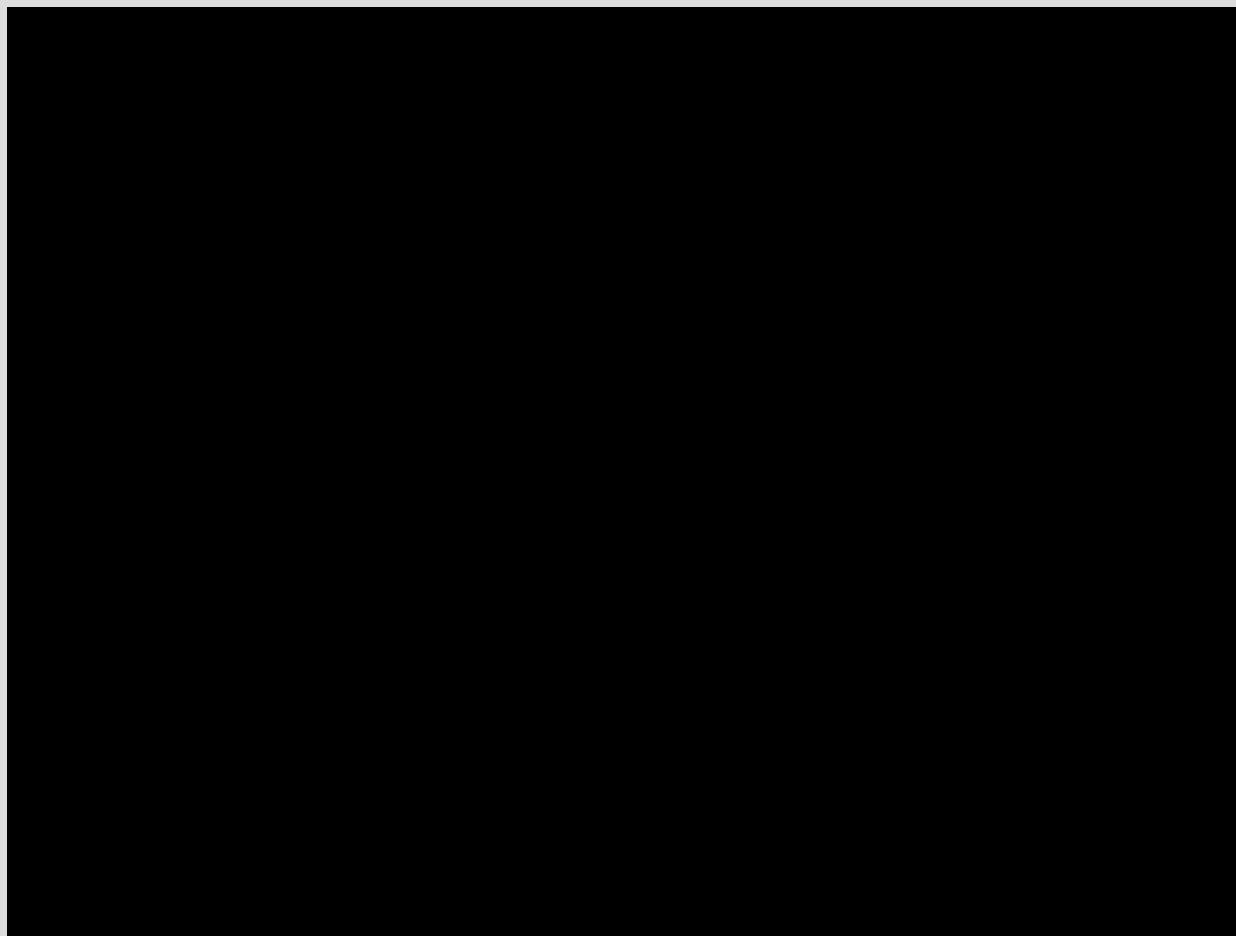



Thank you for attention

www.jasic.org

R51

Test procedure for vehicles having at least four wheels

Y. Shirahashi

JASIC Noise-sub committee

Overview of R51 Test Procedure

Common
Different

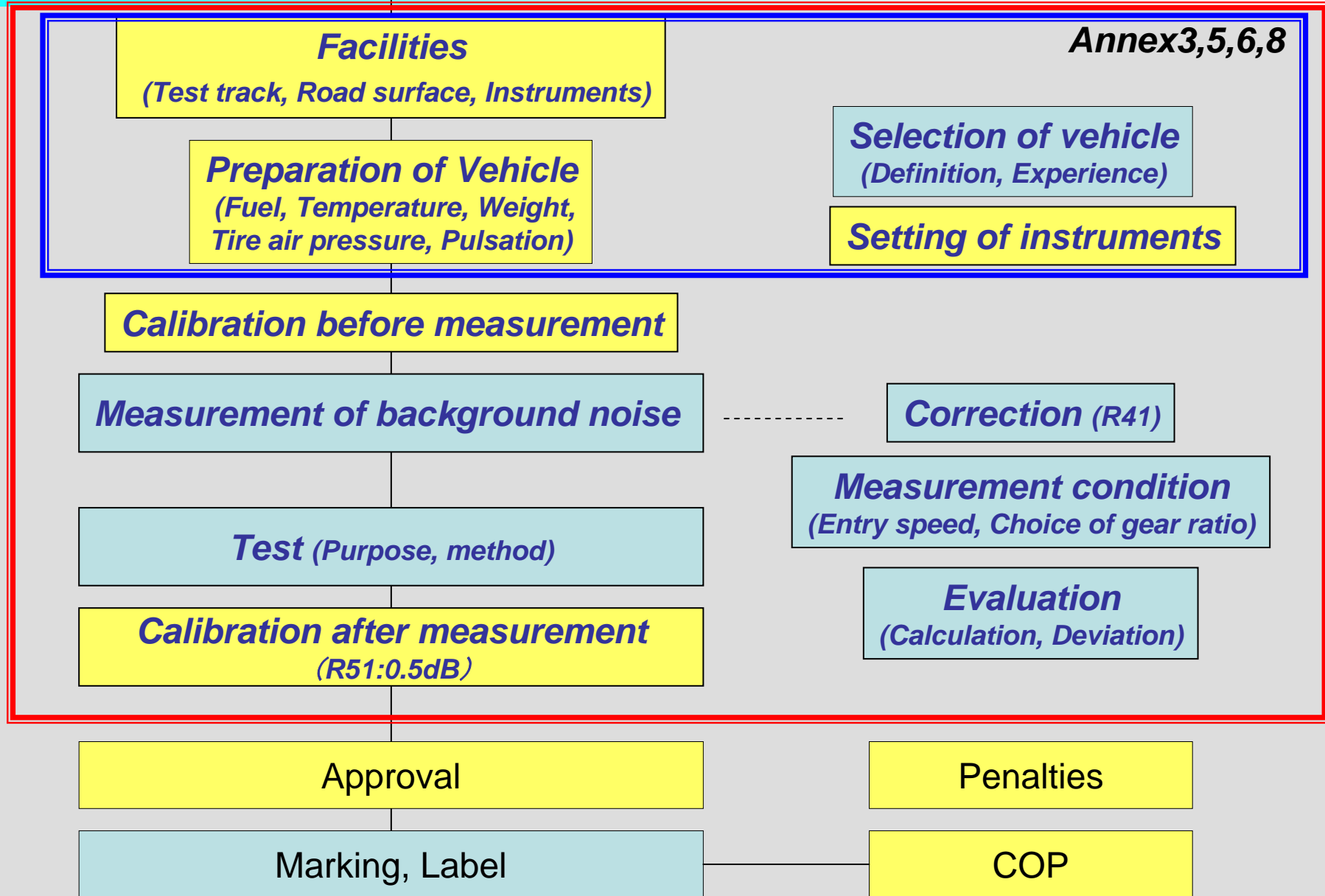

Test facilities & instruments



R51 requires same specification as R41 for test site and instruments except for an accuracy of the engine speed and the vehicle speed. They shall be measured with instruments with an accuracy of +/- 2% or better.

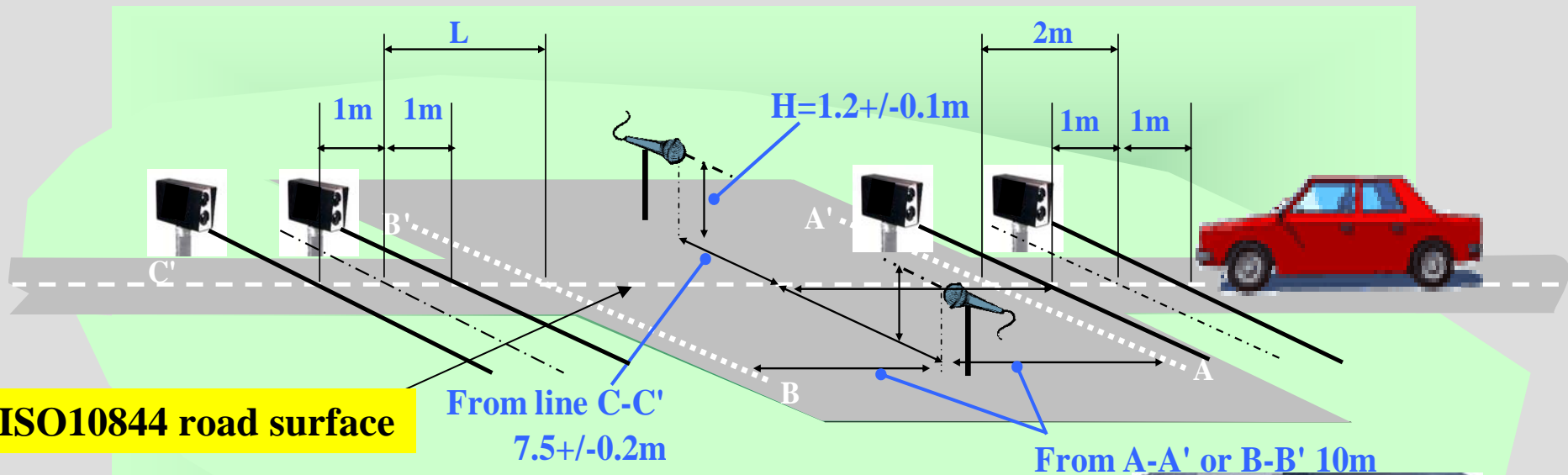

ISO10844 road surface

From line C-C'
7.5 +/- 0.2m

From A-A' or B-B' 10m

Requirement of sound meter.

- According to IEC standards.
- **"FAST"** response
- **"A"** weighting

Maximum sound level during acceleration shall be Measured. (e.g. **Using peak hold or using a level recorder**)

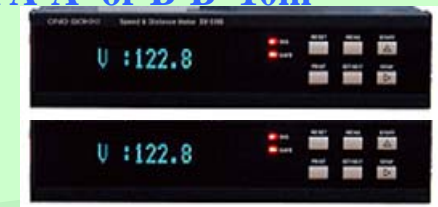

Accuracy of vehicle speed measurement :
+/- 2%

(Note: +/- 3% in R41)

Selection of vehicle



Item	Contents	Selected test vehicle
Engine	Type of engine (See next slide)	Each type
Transmission	Type and number of gears	
Noise reduction system	Exhaust/ intake system etc. (See next slide)	

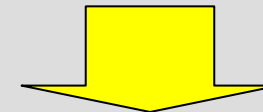

1. Type of engine

- positive or compression ignition
- two-stroke or four-stroke
- piston engine or rotary-piston engine
- number and capacity of cylinders
- number and type of carburetors or injection systems
- arrangement of valves
- rated maximum power and corresponding engine speed
- type of electric motor



Selection of vehicle

2. Noise reduction system(s)

- trade names or marks
- the characteristics of the materials constituting a component, shape or size
- Operating principles
- the number of the intake and/or exhaust silencers

3. Noise reduction system (s) component

- the exhaust pipings, the expansion chamber(s), the silencer(s)
- The air filter is considered as a component only if its presence is essential to ensure observance of the prescribed sound-level limits
- Manifolds are not considered components of the noise reduction system.

Preparation of test vehicles



Vehicle mass

Measurements shall be made on unladen vehicles and, except in the case of nonseparable vehicles, without trailer or semi-trailer.

Unladen + 75kg without trailer(or curb mass + 75kg)

Tire

The tyres used for the test are selected by the vehicle manufacturer; they shall correspond to one of the tyre sizes designated for the vehicle by the vehicle manufacturer.

The tyres must **be inflated to the pressure**(s) appropriate to the test mass of the vehicle.

Exhaust system

If the vehicle is equipped with **an exhaust system containing fibrous materials**, the exhaust system is to be conditioned before the test **according to annex 5**.

Refer to 2.2.1, 2.2.2, 2.2.6

Preparation of test vehicles



Before the measurements

- The vehicle shall be brought to its normal operating conditions - temperatures etc.
- If the vehicle is fitted with more than two-wheel drive, it shall be tested in the drive which is intended for normal road use.

Overview of R51 Test Procedure

Common
Different

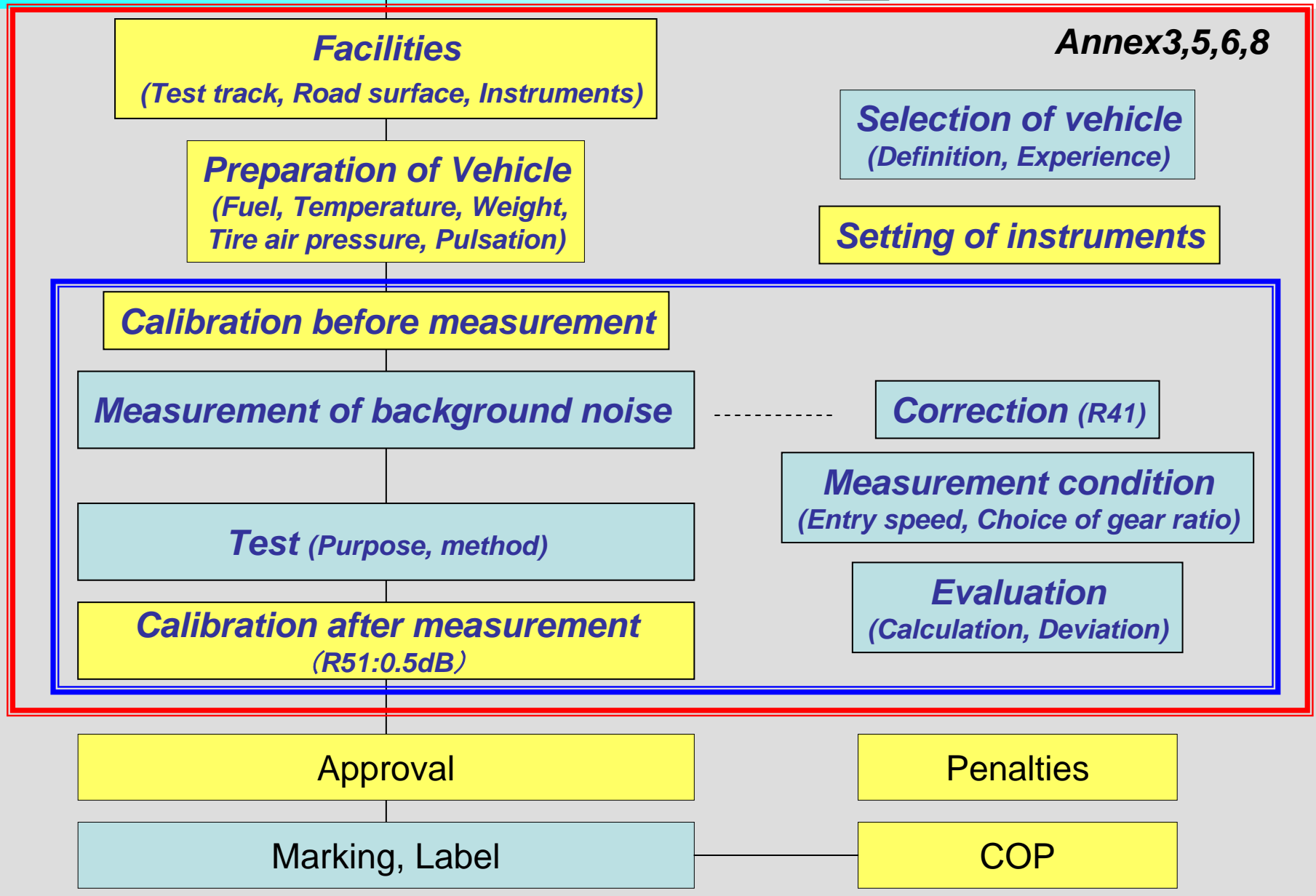

Test Methods in R51



Categories		Acceleration (in motion)		Stationary	
		MT	AT	Proximity exhaust noise	Compressed air noise
M1		Method 1	Method 2	Method 4	
	High performance ⁽¹⁾	Method 1'			
N1		Method 1	Method 2		Method 5 ⁽²⁾
M2,M3		Method 3	Method 2		
N2,N3					

- (1) The vehicles fitted with a gear box having more than four forward gears and equipped with an engine developing a maximum power **greater than 140 kW** and having a maximum-power/maximum mass ratio **greater than 75 kW/t**, and the speed at which the rear of the vehicle passes **the line BB' in third gear is greater than 61 km**.
- (2) For the vehicles having a maximum permissible mass exceeding 2,800 kg and **having compressed air brake**. This method was introduced in R51/02.

Flow of test procedure

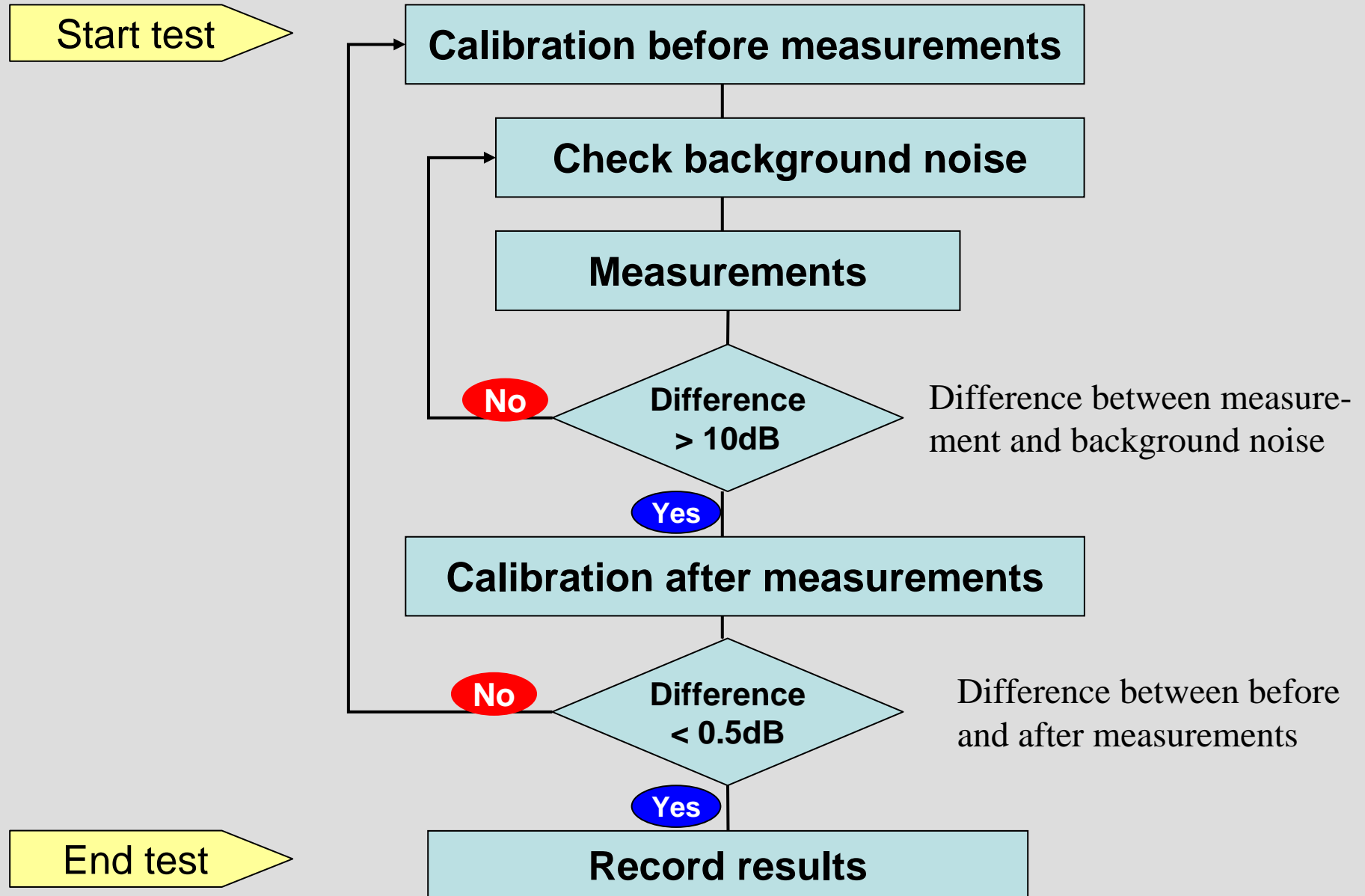

Test Method for Acceleration Noise (ECE R51)



Common procedures

● : Microphone

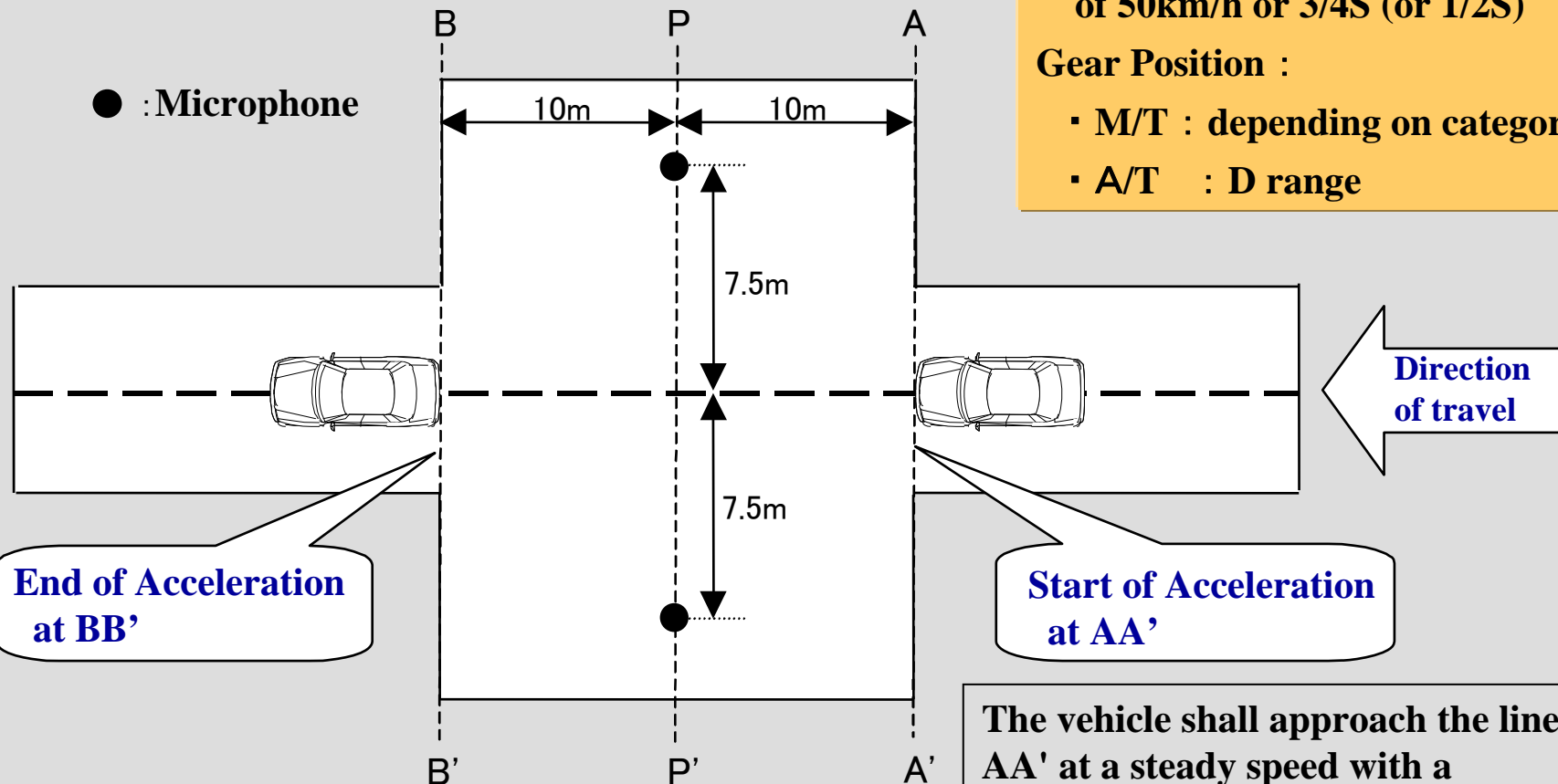

Approach Speed : The lower of 50km/h or 3/4S (or 1/2S)

Gear Position :

- M/T : depending on category
- A/T : D range

The vehicle shall approach the line AA' at a steady speed with a **tolerance +/- 1km/h**; except where the controlling factor is engine speed the tolerance shall be the larger of +/- 2% or +/- 50min⁻¹

Test procedures



Vehicle in motion (Sample)



Test procedure for M1 and N1



Manual transmissions

Approach speed

$$V_A = 50 \text{ km/h} \text{ or } N_A = 3/4 S$$

whichever is the lower vehicle speed

Categories		Acceleration	
		MT	AT
M1		1	2
	H.P.	1'	
N1		1	2
M2,M3		3	2
N2,N3			

Gear position

- Vehicles fitted with a gearbox having **four or less forward gears** to be tested **in second gear**.
- Vehicles fitted with a gearbox having **more than four forward gears** to be tested successively **in second and third gear**.
- If during the test in second gear, **the engine speed exceeds the rated engine speed, S**, at which the engine develops its rated maximum power, the test must be repeated with an approach speed and/or **approach engine speed reduced by steps of 5%S**, until the engine speed attained no longer exceeds S.
- If the engine speed S is still attained with an approach speed corresponding to the idle speed, then the test will be performed **only in third gear**.

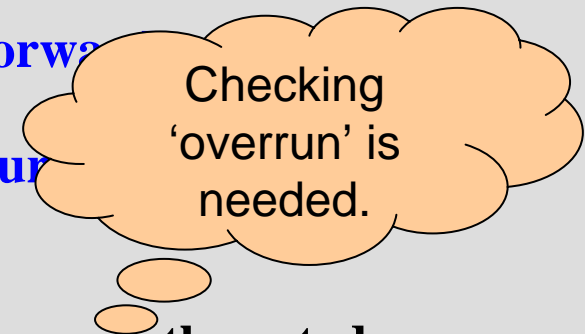

How to check Overrun

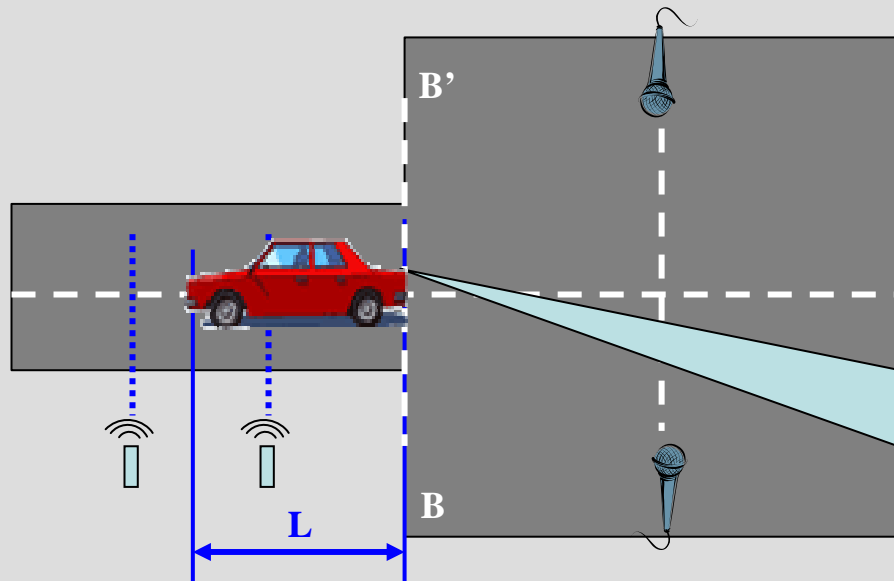

Categories		Acceleration	
		MT	AT
M1		1	2
	H.P.	1'	
N1		1	2
M2,M3		3	2
N2,N3			

If engine speed exceeds S when the rear end of the vehicle reaches to BB', have to consider V_A and gear position.

Engine speed shall be checked, If engine speed measurement is not available, the following equation should be used.

$$\text{Overrun vehicle speed} = \frac{(\text{rated engine speed (rpm)}) \times \pi \times (\text{tire diameter})}{60 \times (\text{gear ratio}) \times (\text{reduction ratio})}$$

Vehicle speed at BB'+L > over-run vehicle speed

Test procedure for M1 and N1



High performance vehicles with manual transmission

Categories		Acceleration	
		MT	AT
M1		1	2
	H.P.	1'	
N1		1	2
M2,M3		3	2
N2,N3			

The vehicles of **category M1** having more than four forward gears and equipped with an engine developing a maximum-power **greater than 140 kW** and a permissible maximum-power/maximum-weight ratio **greater than 75 kW/t** shall be tested **only in third gear**, provided that the speed at which the rear of the vehicle passes the **line BB' in third gear is greater than 61 km/h**.

Test procedure for M1 and N1



Automatic transmissions with manual selector

Categories	Acceleration	
	MT	AT
M1	1	2
	H.P.	1'
N1	1	2
M2,M3	3	2
N2,N3		

Approach speed

$V_A = 50 \text{ km/h}$ or $N_A = 3/4 S$
whichever is the lower vehicle speed

Gear position

- **Position of the manual selector**

The test shall be conducted with the selector in the position recommended by the manufacturer for **'normal' driving (= D range)**.

- **Auxiliary gears**

If the vehicle is fitted with an auxiliary manual transmission or a multi-gear axle, **the position used for normal urban driving** shall be used.

- **External downshifting** (for example kick down) shall **be excluded**.

Refer to 3.1.2.4.2.1. 3.1.2.4.2.2., 3.1.2.4.2.3., 3.1.2.4.2.4.,

AT with manual selector



Test procedure for M1 and N1



Automatic transmissions with manual selector

Approach speed

$V_A = 50 \text{ km/h}$ or $N_A = 3/4 S$
whichever is the lower vehicle speed

Gear position

- **Position of the manual selector**

The test shall be conducted with the selector in the position recommended by the manufacturer for **'normal' driving (= D range)**.

- **Auxiliary gears**

If the vehicle is fitted with an auxiliary manual transmission or a multi-gear axle, **the position used for normal urban driving** shall be used.

- **External downshifting** (for example kick down) shall **be excluded**.

Categories	Acceleration	
	MT	AT
M1	1	2
	H.P.	1'
N1	1	2
M2,M3	3	2
N2,N3		

External downshifting



The example of the kick down switch for external downshifting.



Kick down
switch

Test procedure for M1 and N1



Prevention of downshift

If during the test, in the case of vehicles having more than two separate gears, there is an automatic **down-shift to first gear**, this down-shift may be avoided, at the manufacturer's choice. In these cases the operator may select any of the following modifications:

- a) increase the vehicle speed v to a maximum of 60km/h;
- b) maintain the vehicle speed v at 50km/h and limit the fuel supply to the engine to 95% of the supply necessary for full load; this condition is considered to be satisfied;
 - (i) in the case of a spark-ignition engine, when the angle of the throttle opening is 90% of the full angle,
 - (ii) in the case of a compression-ignition engine, when the fuel supply to the injection pump is limited to 90% of its maximum supply;
- c) establish and use an electronic control that will prevent a downshift to gears lower than those used in normal urban driving as defined by the manufacturer.

Categories		Acceleration	
		MT	AT
M1		1	2
	H.P.	1'	
N1		1	2
M2,M3		3	2
N2,N3			

Refer to 3.1.2.4.2.4.,

Test procedure for M1 and N1



Prevention of downshift

EU Directive

If during the test, in the case of vehicles having more than two separate gears, there is an automatic **down-shift to first gear**, this down-shift may be avoided, at the manufacturer's choice. In these cases the operator may select any of the following modifications:

R51/02

Some vehicles equipped with an automatic transmission (two or more discrete ratios) may downshift to a gear ratio not normally used in urban driving, as defined by the manufacturer. In these cases the operator may select any of the following modifications

Categories	Acceleration	
	MT	AT
M1	1	2
	H.P.	1'
N1	1	2
M2,M3	3	2
N2,N3		

Test procedure for M2, M3, N2, and N3



Manual transmissions

Categories		Acceleration	
		MT	AT
M1		1	2
	H.P.	1'	/
N1		1	2
M2,M3		3	2
N2,N3			

Approach speed

- The rated engine power not greater than 225kW
 $V_A = 50 \text{ km/h}$ or $N_A = 3/4 \text{ S}$
whichever is the lower vehicle speed
- The rated engine power greater than 225kW
 $V_A = 50 \text{ km/h}$ or $N_A = 1/2 \text{ S}$
whichever is the lower vehicle speed

Test procedure for M2, M3, N2, and N3



Manual transmissions

Categories		Acceleration	
		MT	AT
M1		1	2
	H.P.	1'	/
N1		1	2
M2,M3		3	2
N2,N3			

Gear position

- Vehicles, in which the **total number of forward gear ratios is x** (including those obtained by way of an auxiliary transmission or a multi-gear axle) will be tested sequentially, using **the ratio equal to or higher than x/n** .

Where: **$n = 2$** for vehicles having an engine power **not greater than 225 kW**

$n = 3$ for vehicles having an engine power **greater than 225 kW**

- If x/n does not correspond to a whole number, the nearest higher ratio must be used.
- The testing shall continue from the gear (x/n) to the next higher gear.
- Shifting up gear ratios from (x/n) shall be terminating when in **the gear X in which the rated engine speed is reached just before the rear of the vehicle has passed the line BB'**.

Test procedure for M2, M3, N2, and N3



Categories		Acceleration	
		MT	AT
M1		1	2
	H.P.	1'	/
N1		1	2
M2,M3		3	2
N2,N3			

Example of selection of gear ratio

- Sample Calculation for Testing: There are **16 forward ratios** for drive train having a transmission with 8 gears and an auxiliary transmission with 2 gears. If the engine has **230kW** then $(x/n) = (8 \times 2)/3 = 16/3 = 5 \frac{1}{3}$. The initial test gear ratio is **6th** (includes the gears from both the main transmission and auxiliary which is **6th** out of the 16 total gear ratios), with **the next gear ratio is 7th** up to ratio X.
- The highest sound level is obtained between the extreme ratios tested.

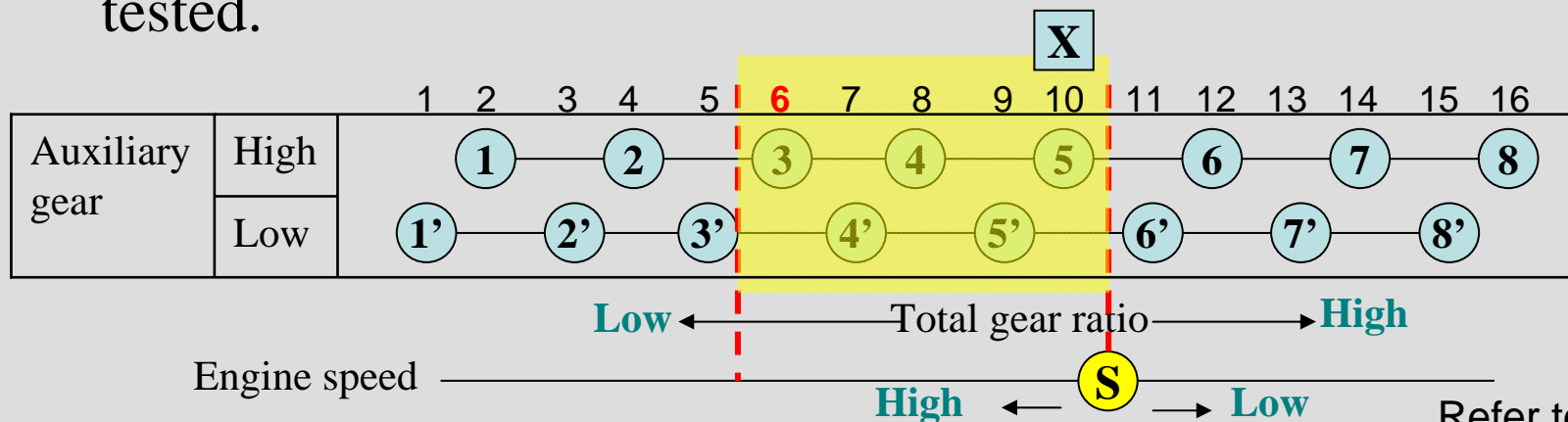

Refer to 3.1.2.3.2.3.

Test procedure for M2, M3, N2, and N3



Automatic transmissions with manual selector

Categories		Acceleration	
		MT	AT
M1		1	2
	H.P.	1'	
N1		1	2
M2,M3		3	2
N2,N3			

Approach speed

- The rated engine power not greater than 225kW

$$V_A = 50 \text{ km/h} \text{ or } N_A = 3/4 \text{ S}$$

whichever is the lower vehicle speed

- The rated engine power greater than 225kW

$$V_A = 50 \text{ km/h} \text{ or } N_A = 1/2 \text{ S}$$

whichever is the lower vehicle speed

Gear position

Same as M1 and N1

Test procedure for all categories



Automatic transmissions without manual selector

Categories		Acceleration	
		MT	AT
M1		1	2
	H.P.	1'	
N1		1	2
M2,M3		3	2
N2,N3			

Approach speed

- The vehicle shall approach the line AA' at various uniform speeds of **30, 40, 50 km/h** or at **3/4 of the maximum on-road speed** if this value is lower.
- The condition giving the highest noise level shall be retained.

Test procedure for All categories



Electrical motor vehicles (with no gearbox)

In the case of vehicles powered by an electric motor

$$V_A = \frac{3}{4} V_{\max} \text{ or } V_A = 50 \text{ km/h,}$$

whichever is the lower.

V_{\max} : maximum speed declared by the vehicle manufacturer.

Interpretation of test results



- The measurement of noise emitted by the vehicle in motion shall be considered valid if the difference between the **two consecutive measurements** on the same side of the vehicle is not more than 2dB(A).
- The figure recorded shall be that corresponding to **the highest sound level**.
- To allow for lack of precision in the measuring instrument the figures read from it during measurement shall each be **reduced by 1dB**.

Demonstration (Acceleration test)



Method 1

	1	2	3	Max Sound Level	Intermediate result
2nd gear					
V_A					
V_B					
L/H					
R/H					
3rd gear					
V_A					
V_B					
L/H					
R/H					

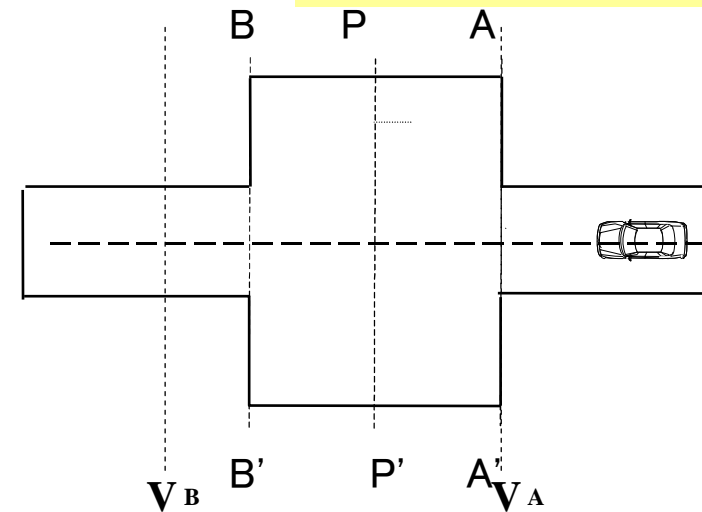

Demonstration (Acceleration test)



Method 1

	1	2	3	Max Sound Level	Intermediate result
2nd gear					
V_A	50.5				
V_B	60.0				
L/H	75.5				
R/H	74.8				
3rd gear					
V_A					
V_B					
L/H					
R/H					

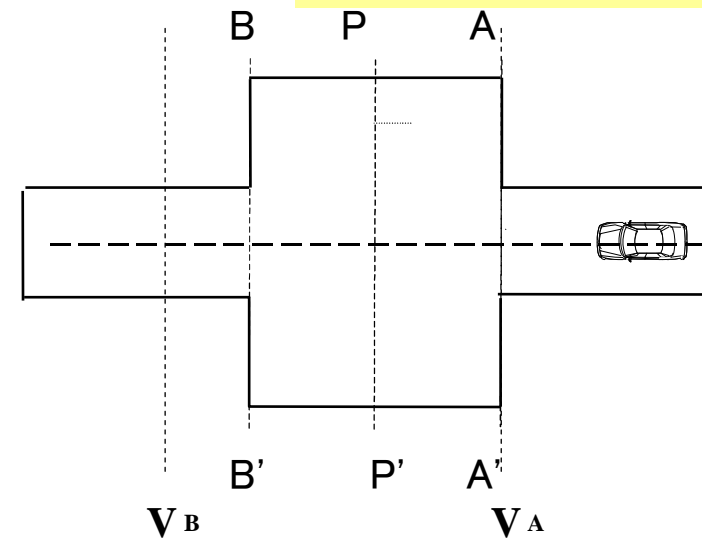

Demonstration (Acceleration test)



Method 1

	1	2	3	Max Sound Level	Intermediate result
2nd gear					
V_A	50.5	52.0			
V_B	60.0	62.0			
L/H	75.5	76.0			
R/H	74.8	75.5			
3rd gear					
V_A					
V_B					
L/H					
R/H					

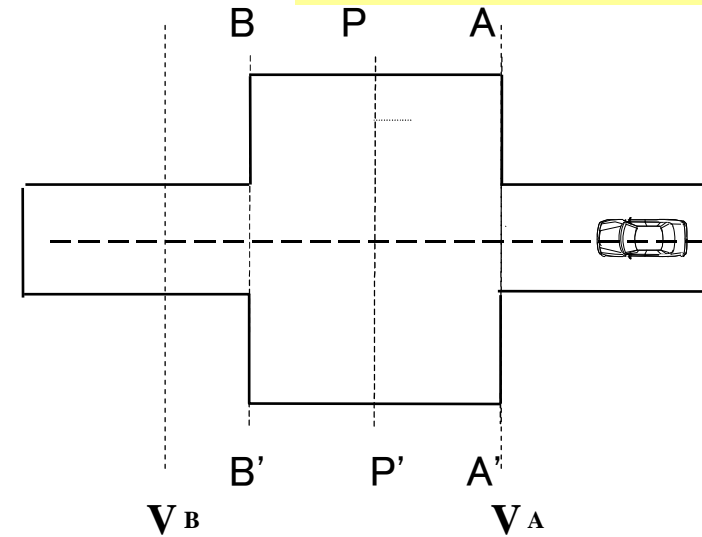

Demonstration (Acceleration test)



Method 1

	1	2	3	Max Sound Level	Intermediate result
2nd gear					
V_A	50.5	52.0			
V_B	60.0	62.0			
L/H	75.5	76.0			
R/H	74.8	75.5			
3rd gear					
V_A					
V_B					
L/H					
R/H					

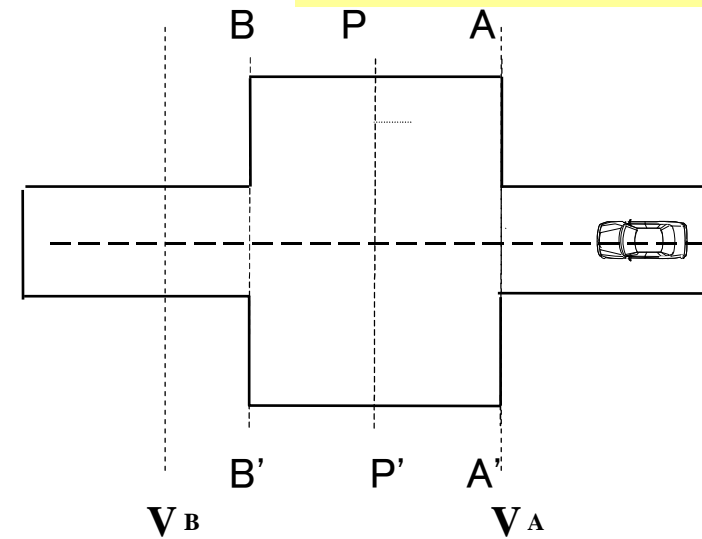

Demonstration (Acceleration test)



Method 1

	1	2	3	Max Sound Level	Intermediate result
2nd gear					
V_A	50.5	52.0	51.0		
V_B	60.0	62.0	61.0		
L/H	75.5	76.0	75.5		
R/H	74.8	75.5	75.0		
3rd gear					
V_A					
V_B					
L/H					
R/H					

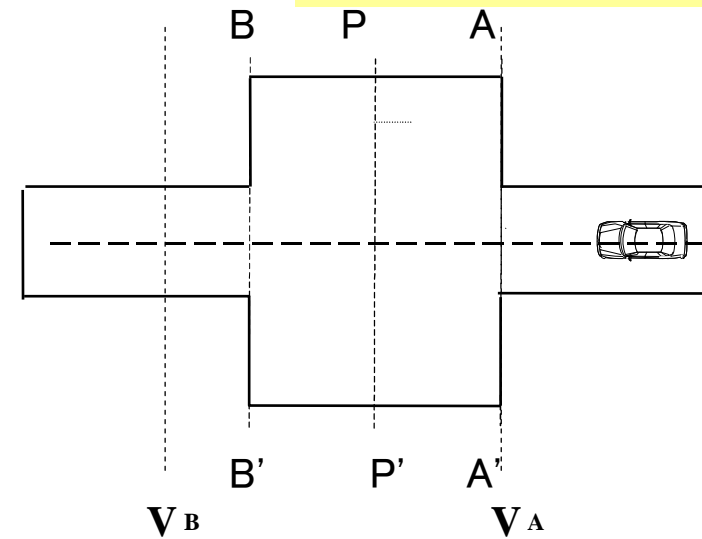

Demonstration (Acceleration test)



Method 1

	1	2	3	Max Sound Level	Intermediate result
2nd gear					
V_A	50.5	52.0	51.0		
V_B	60.0	62.0	61.0		
L/H	75.5	76.0	75.5		
R/H	74.8	75.5	75.0		
3rd gear					
V_A	50.0				
V_B	58.5				
L/H	69.0				
R/H	70.0				

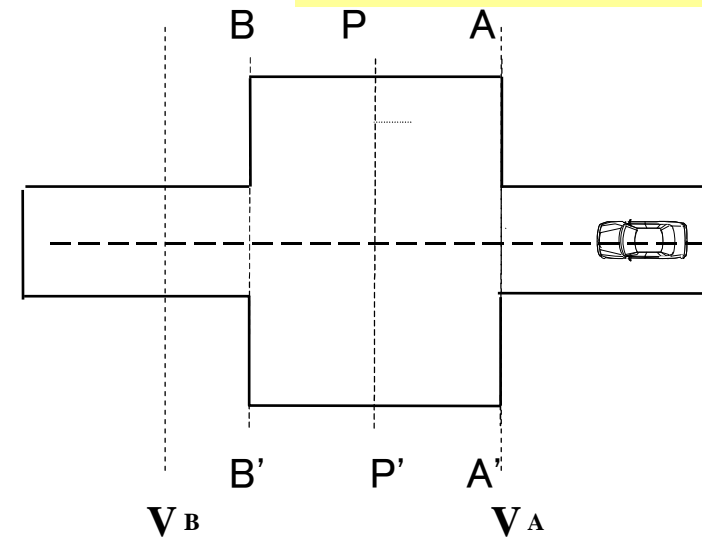

Demonstration (Acceleration test)



Method 1

	1	2	3	Max Sound Level	Intermediate result
2nd gear					
V_A	50.5	52.0	51.0		
V_B	60.0	62.0	61.0		
L/H	75.5	76.0	75.5		
R/H	74.8	75.5	75.0		
3rd gear					
V_A	50.0	50.8			
V_B	58.5	59.0			
L/H	>2dB	71.5			
R/H	70.0	71.5			

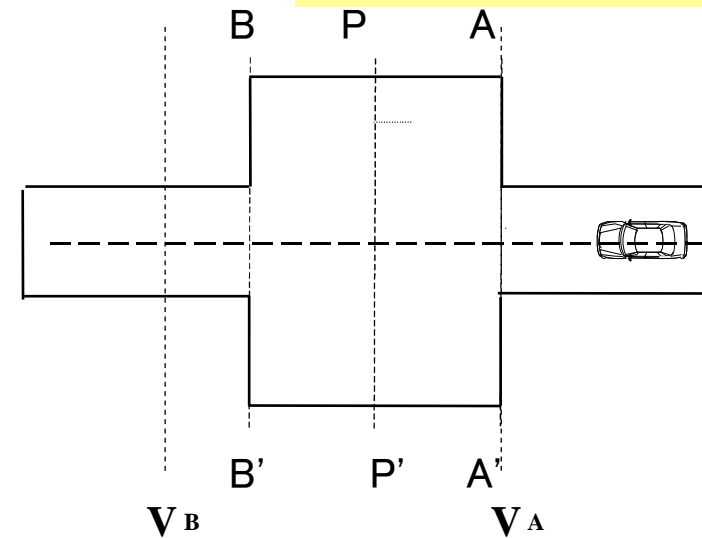

Demonstration (Acceleration test)



Method 1

	1	2	3	Max Sound Level	Intermediate result
2nd gear					
V_A	50.5	52.0	51.0		
V_B	60.0	62.0	61.0		
L/H	75.5	76.0	75.5		
R/H	74.8	75.5	75.0		
3rd gear					
V_A	50.0	50.8	50.5		
V_B	58.5	59.0	58.5		
L/H	69.0	71.5	71.0		
R/H	70.0	71.5	71.0		

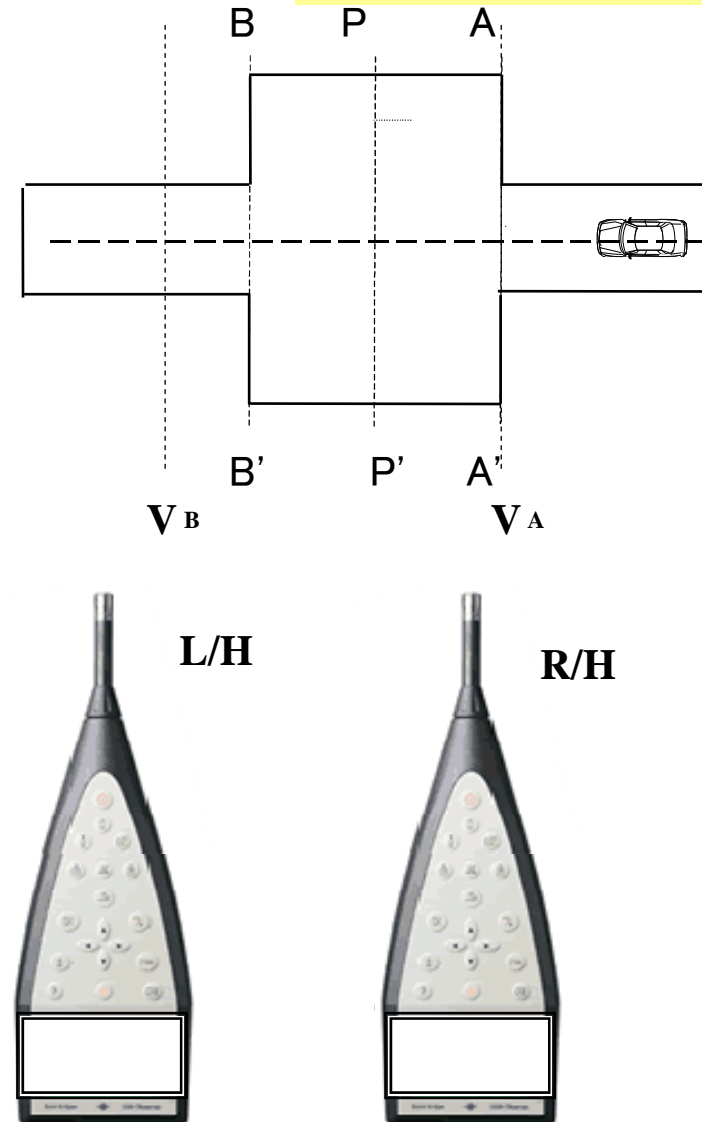

Demonstration (Acceleration test)



Method 1

	1	2	3	Max Sound Level	Intermediate result
2nd gear	Maximum of two runs on the same side			Maximum of L/H and R/H side	
V _A					
V _B	60.0	62.0			
L/H	75.5	76.0	75.5	75.5	75.5
R/H	74.8	75.5	75.0	75.0	
3rd gear					
V _A	50.0	50.8	50.5		
V _B	58.5	59.0	58.5		
L/H	69.0	71.5	71.0	71.5	71.5
R/H	70.0	71.5	71.0	71.5	

Final Result : $\frac{75.5+71.5}{2} = 73.5$

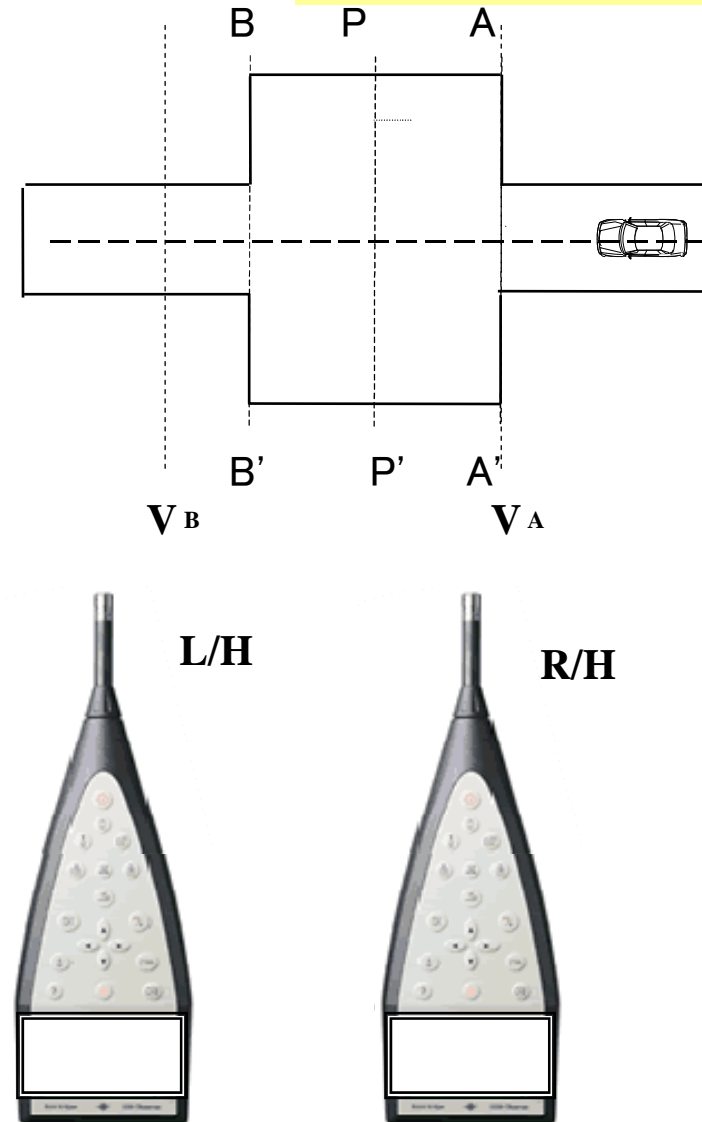

Limit Values R51/02



Categories			Limit values				
				(1)	(2)	(3)	
M1	Passenger car (number of seat ≤ 9)		74	+1	+1	+1	
M2 & M3	Buses (number of seat > 9)	GVM $\leq 2t$	76		+1		
		2t $<$ GVM $\leq 3.5t$	77		+1	+1	
		3.5t $<$ GVM	P $<$ 50kW	78			+1
			150kW \leq P	80			+2
N1	Trucks	GVM $\leq 2t$	76		+1		
		2t $<$ GVM $\leq 3.5t$	77		+1	+1	
N2		3.5t $<$ GVM	P $<$ 75kW	77		+1	
			75kW \leq P $<$ 150kW	78		+1	
		3.5t $<$ GVM $\leq 12t$	150kW \leq P	80			+2
12t $<$ GVM	80				+2		

(1) High performance car(See test method)

(2) Direct injection diesel engine

(3) Off-road which is defined in R.E.3

and 2t $<$ GVM

Test Method for Stationary Exhaust Noise Test (ECE R51)



Method 3

Vehicle in stationary (Sample)



Purpose of stationary noise



Aim of stationary noise test is mentioned in UN/ECE /WP29 RE3.

1.5.1.2. Methods of measuring the sound level.

..... **The test on the vehicle when stationary** may usefully be taken as a reference value by technical services wishing **to use this method to check vehicles in service.**

.....

1.5.2.2. In view of the tolerances of measuring instruments, the disturbances that may occur at the time of measurement and the scatter of measurements for vehicles of the same type, it will TRANS/WP.29/78/Rev.1 be **necessary to allow for a margin of 5 dB(A) in comparison with the corresponding value recorded at the time of the type approval.**

in use noise enforcement in national regulation level.

It may be used with at least **5dB for margin.**

Test instruments



Method 3

Method 4

For sound measurement

A precision sound-level meter shall be used.
(refer to IEC standard)

- **“A”** weighting
- **“FAST”** response
- **Peak hold** (or maximum hold)



For engine speed measurement

Engine tachometer

Accuracy +/-2%

(Note: +/- 3% in R41)



Refer to 1.1, 1.2.

Setting of Microphone



Method 3

The height: same as **the height of the outlet pipe** but minimum value of 0.2 m.

Distance: **0.5 m** from the exhaust orifice

Angle: **45 degrees** +/- 10 degrees in the direction of the gas flow.

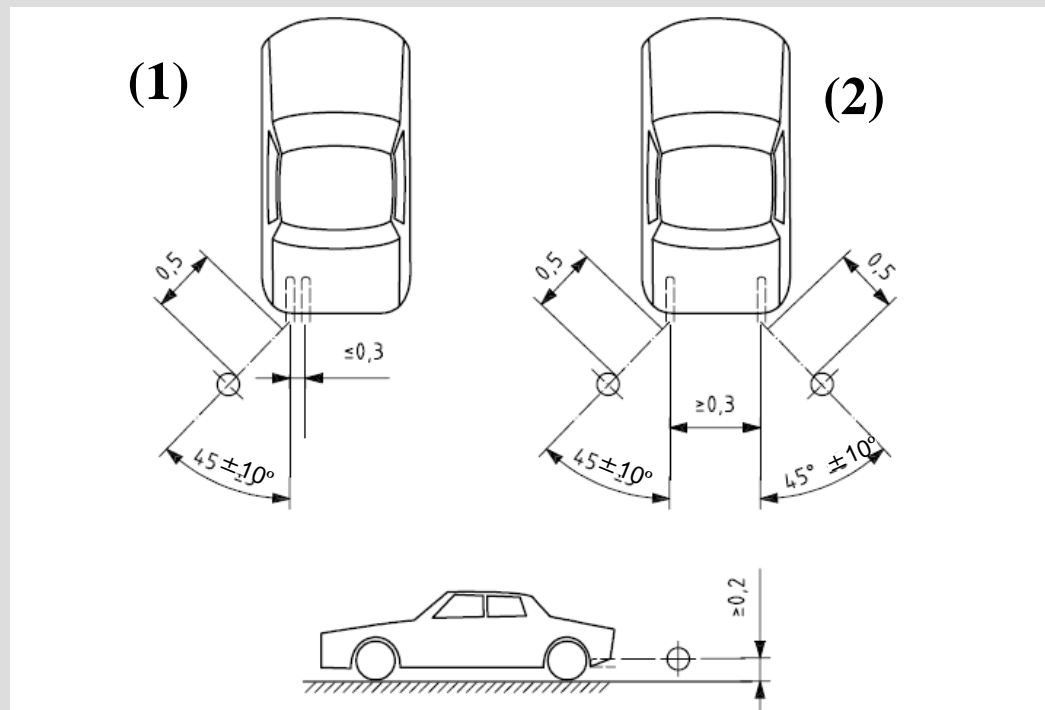

(1) Two or more outlets spaced less than 0.3 m apart

only one measurement is made; the microphone position is related to the outlet nearest to one extreme edge of the vehicle.

(2) Outlets spaced more than 0.3 m apart,

one measurement is made for each outlet

Refer to 3.2.5.3.1

Setting of Microphone



Method 3

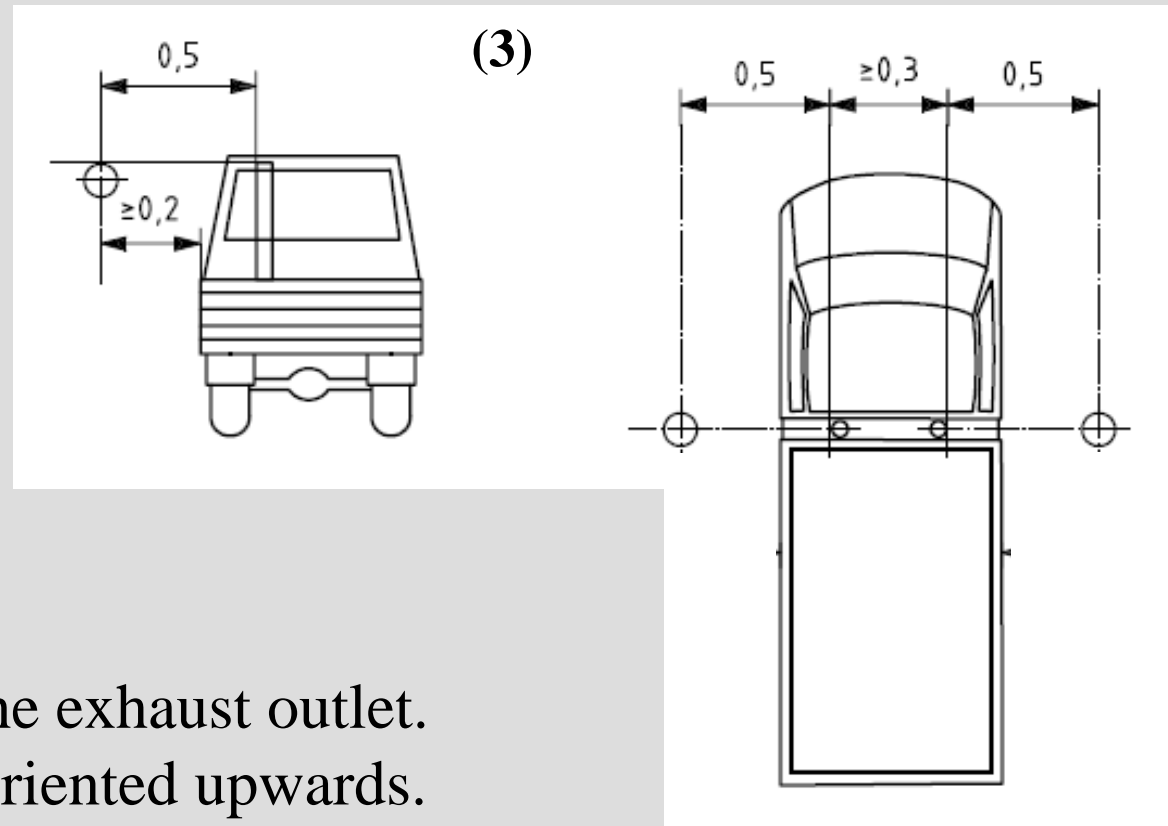

(3) Vertical exhaust

Height: height of the exhaust outlet.

Axis: vertical and oriented upwards.

Distance: 0.5 m from the side of the vehicle nearest to the exhaust.

Test procedure



Method 3

Operating condition

The engine is operated at a **constant speed of 3/4 S.**

When constant engine speed is reached, the throttle shall be **returned swiftly to the idle position.**

The sound level shall be measured during a period of constant engine speed and throughout the entire deceleration period.

The maximum sound level meter reading being taken as the test value.

Interpretation of test results

Readings, **rounded off to the nearest decibel**, shall be taken from the measuring instrument.

Only those values obtained from **three consecutive measurements** which do not differ by more than 2 dB(A).

The highest of these three values shall constitute the test result.

Test Method for Compressed Air Noise Test (ECE R51)



Method 4

Operating condition

The highest A-weighted noise level is registered during venting the pressure regulator and during ventilating after the use of both the service and parking brakes.

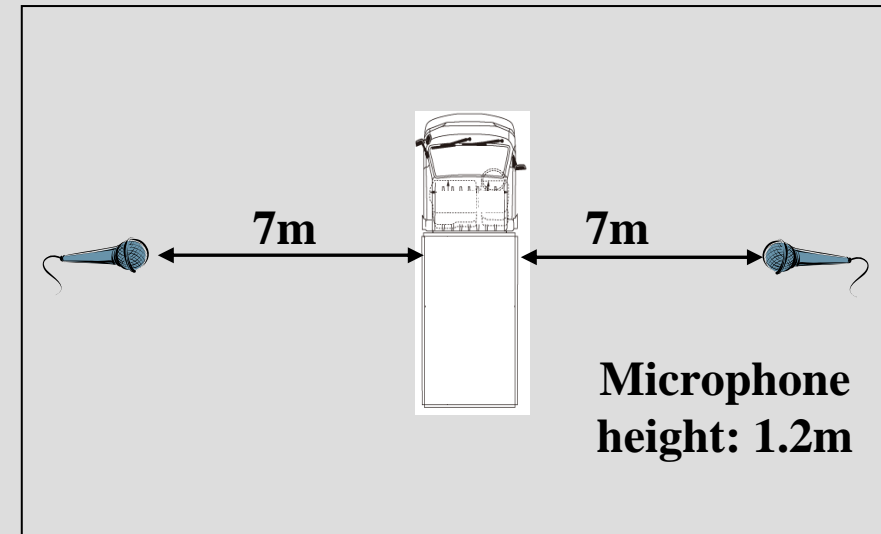

The noise during venting the pressure regulator is measured with the engine at idling speed.

The air-compressor unit has to be brought up to the highest permissible operating pressure, and then the engine switched off.

The ventilating noise is registered while operating the service and parking brakes



Compressed air noise

Method 4

Interpretation of test results

For all microphone positions **two measurements** are taken. In order to compensate for inaccuracies of the measuring equipment, the meter reading is **reduced by 1 dB(A)**. **The highest value** measured is taken as the results.

Limit value

Limit value: **72dB(A)**

Important points



The important points for correct noise data

1. Carrying out calibration of the sound level meter in every test.
2. Taking care of low and stable ambient noise
3. Reducing the factors for variation of noise level;
 - Approach speed (+/- 1km/h)
 - Timing (place) of wide-open -throttle (as close to AA' line as possible)
 - Stability of opening the throttle during measurement to in stationary test
4. Selection and maintenance of road surface for noise test

Comparison of Road Surfaces



ISO surface

(maximum chipping size 8mm)

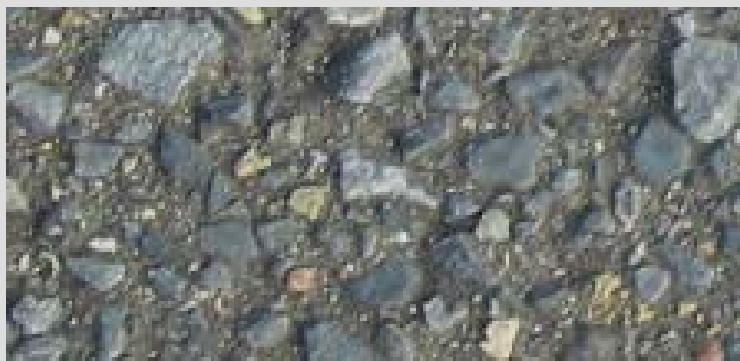

Dense asphalt concrete

(maximum chipping size 13mm)

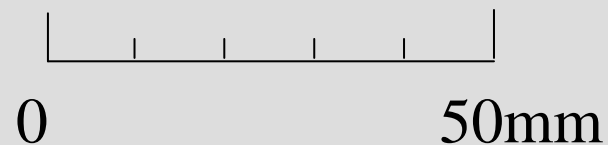

Road surface



The road surface for noise test was standardized by ISO (ISO10844). Then, ECE adopted ISO10844 for R51/02.

- **The purpose of specified test surface** (so called 'ISO surface')
Reducing the variation of noise level, because the road surface is one of most important factor for noise level.

- **Requirements for road surface**

<Materials> 8mm of maximum chipping size

Straight asphalt for the binder

<Characteristics> Texture depth $\geq 0.4\text{mm}$,

Void content $\leq 8\%$ (Absorption coefficient ≤ 0.1)

<Maintenance> Texture depth shall be checked every year.

- **Remarks**

Problem of durability in the high temperature areas due to using straight asphalt

Under revising ISO 10844 (We expect to be able to use modified asphalt)



***Thank you very much
for your attention***



General information

R43

Asia Expert Meeting

Masaru Morikawa
JASIC

What is R43



- R43 is a
“UNIFORM PROVISIONS CONCERNING THE APPROVAL OF SAFETY GLAZING MATERIALS AND THEIR INSTALLATION ON VEHICLES”

Original version was adopted in 1981.

UN organization



- R43 is discussed by UN/ECE/WP29/GRSG

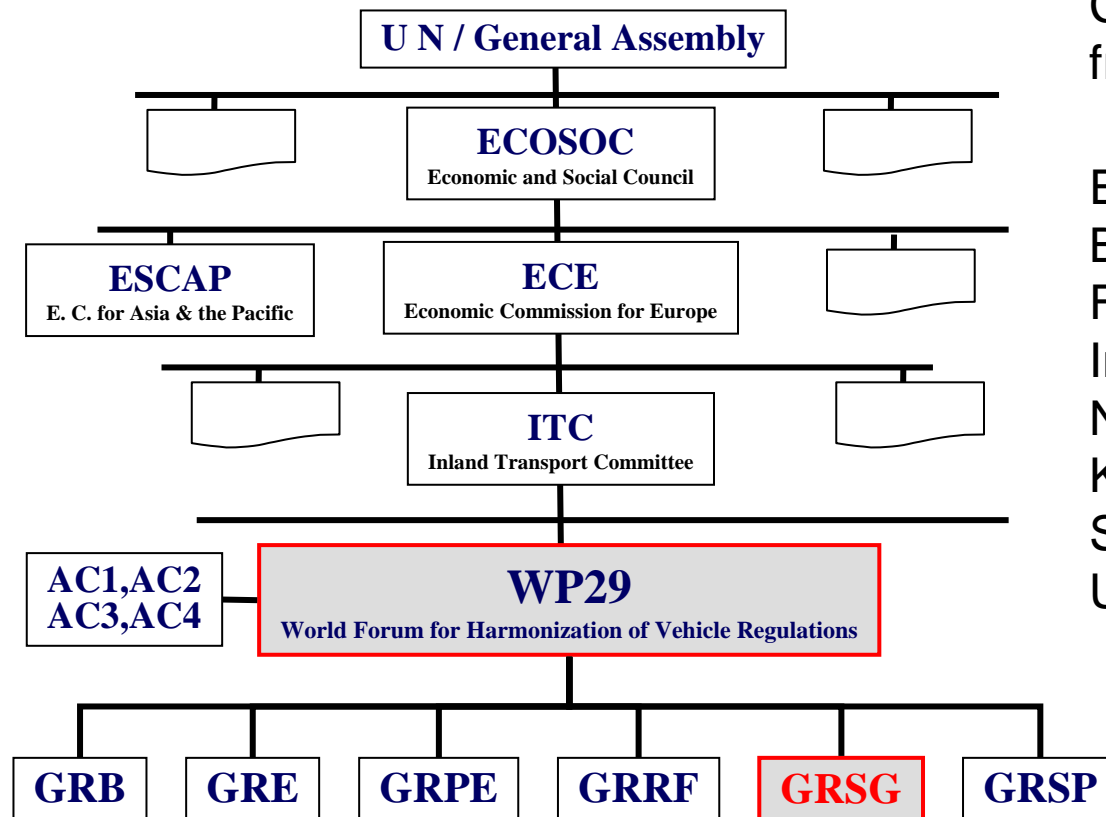

Chaired by Mr. Antonio Erario
from Italy

Experts from;
Belgium; Canada; Czech Republic;
Finland; France; Germany; Hungary;
India; Italy; Japan; Luxembourg;
Netherlands; Norway; China; Poland;
Korea; Russia; South Africa; Spain;
Sweden; Switzerland; Thailand;
UK; USA; EU

Participation from NGO
OICA; IMMA; IRU, CLCCR and
VERONICA project

Adoption of R43



- R43 has been adopted by 41 contracting party.
- There are 34 administrative department and 53 technical services.

(ECE/TRANS/WP.29/343/Rev.16)

ECE symbol	Contracting Parties	Date of application	Designated Administrative Department(s)	Designated Technical Service(s)
E 1	GERMANY	15.02.81	1/A	1/E; 1/G; 1/H
E 2	FRANCE	15.02.81	2/A	2/E
E 3	ITALY	13.11.81	3/A	3/B (a) to (m)
E 4	NETHERLANDS	21.06.85	4/A	4/A; 4/C; 4/I; 4/N; 4/Q; 4/U
E 5	SWEDEN	18.08.81	5/A	5/B
E 6	BELGIUM	08.03.81	6/A	6/F
E 7	HUNGARY	26.03.84	7/A	7/C; 7/J
E 8	CZECH REPUBLIC	12.09.81	8/A	8/C
E 9	SPAIN	01.11.83	9/A	9/B
E 10	SERBIA	27.04.92	10/A	10/A
E 11	UNITED KINGDOM	15.02.81	11/A	11/A; 11/B; 11/C; 11/E; 11/F; 11/H; 11/L; 11/M; 11/N
E 12	AUSTRIA	27.05.84	12/A	12/B
E 13	LUXEMBOURG	01.05.83	13/A	13/B (a), (b), (c)
E 14	SWITZERLAND			
E 16	NORWAY	24.05.93	16/A	...
E 17	FINLAND	25.09.81	17/A	17/B (c)
E 18	DENMARK ^{1/}	24.03.98	18/A	...
E 19	ROMANIA	03.02.84	19/A	19/B; 19/E; 19/K
E 20	POLAND	13.11.92	20/A	20/F
E 21	PORTUGAL	20.08.90	21/A	21/B
E 22	RUSSIAN FEDERATION	30.06.98	22/A	22/H; 22/I; 22/J; 22/L
E 23	GREECE	03.12.95	23/A	23/A
E 24	IRELAND ^{1/}	24.03.98	24/A	24/B; 24/C; 24/D; 24/E; 24/F; 24/G
E 25	CROATIA	08.10.91	25/A	...
E 26	SLOVENIA	22.12.85	26/A	26/A
E 27	SLOVAKIA	12.09.81	27/A	...
E 28	BELARUS	02.07.95	28/A	28/H; 28/K; 28/N
E 29	ESTONIA	28.12.98
E 31	BOSNIA AND HERZEGOVINA	06.03.92
E 32	LATVIA	18.01.99	32/A	...
E 34	BULGARIA	21.01.00	34/A	34/C
E 36	LITHUANIA	29.03.02	36/A	36/A
E 37	TURKEY	07.07.00	37/A	37/B
E 39	AZERBAIJAN			
E 40	THE FORMER YUGOSLAV REPUBLIC OF MACEDONIA	17.09.91	40/A	...
E 42	EUROPEAN COMMUNITY ^{2/}	24.03.98		
E 43	JAPAN			
E 45	AUSTRALIA			
E 46	UKRAINE	08.10.02	46/A (a), (b)	46/B
E 47	SOUTH AFRICA	17.06.01	47/A	...
E 48	NEW ZEALAND	19.03.02
E 49	CYPRUS ^{3/}	01.05.04
E 50	MALTA ^{3/}	01.05.04
E 51	REPUBLIC OF KOREA			
E 52	MALAYSIA	04.04.06
E 53	THAILAND			
E 56	MONTENEGRO	03.06.06
E 58	TUNISIA			

Contents of R43



1. SCOPE
2. DEFINITIONS
3. APPLICATION FOR APPROVAL
4. MARKINGS
5. APPROVAL
6. GENERAL REQUIREMENTS
7. PARTICULAR REQUIREMENTS
8. TESTS
9. MODIFICATION OR EXTENSION OF APPROVAL OF A TYPE OF SAFETY GLAZING MATERIAL
10. CONFORMITY OF PRODUCTION
11. PENALTIES FOR NON-CONFORMITY OF PRODUCTION
12. TRANSITIONAL PROVISIONS
13. PRODUCTION DEFINITELY DISCONTINUED
14. NAMES AND ADDRESSES OF TECHNICAL SERVICES RESPONSIBLE FOR CONDUCTING APPROVAL TESTS, AND OF ADMINISTRATIVE DEPARTMENTS

Contents of R43



- Annex 1 - Communication concerning approval (or extension or refusal or withdrawal of approval or production definitely discontinued) of a type of safety glazing material pursuant to Regulation No. 43
- Annex 1A - Communication concerning approval (or extension or refusal or withdrawal of approval or production definitely discontinued) of a vehicle type with regard to its safety glazing
- Annex 2 - Arrangements of approval marks for components
- Annex 2A - Arrangements of approval marks for vehicles
- Annex 3 - General test conditions
- Annex 4 - Toughened-glass windscreens
- Annex 5 - Uniformly-toughened glass panes
- Annex 6 - Ordinary laminated-glass windscreens
- Annex 7 - Laminated-glass panes other than windscreens
- Annex 8 - Treated laminated-glass windscreens
- Annex 9 - Safety-glass panes faced with plastics material (on the inside)
- Annex 10 - Glass-plastics windscreens
- Annex 11 - Glass-plastics panes other than windscreens
- Annex 12 - Double-glazed units
- Annex 13 - Grouping of windscreens for approval testing
- Annex 14 - Rigid plastic glazings other than windscreens

Scope



This Regulation applies to:

- (a) safety glazing materials intended for installation as windscreens or other panes, or as partitioning, on vehicles of category L, M, N, O, and T

- (b) vehicles of category M, N and O with regard to the installation of these materials;

Category



Category	Description	Example
L	MOTOR VEHICLES WITH LESS THAN FOUR WHEELS	
M	POWER-DRIVEN VEHICLES HAVING AT LEAST FOUR WHEELS AND USED FOR THE CARRIAGE OF PASSENGERS	
N	POWER-DRIVEN VEHICLES HAVING AT LEAST FOUR WHEELS AND USED FOR THE CARRIAGE OF GOODS	
O	TRAILERS (INCLUDING SEMI TRAILERS)	
T	AGRICULTURAL TRACTORS	

Today's discussion focused on the category M and N.

Type of the glazing



Definitions of type of the each glazing specification are defined in following annexes of this regulation,

Annex 4	TOUGHENED-GLASS WINDSCREENS
Annex 5	<u>UNIFORMLY-TOUGHENED GLASS PANES</u>
Annex 6	<u>ORDINARY LAMINATED-GLASS WINDSCREENS</u>
Annex 7	<u>LAMINATED-GLASS PANES OTHER THAN WINDSCREENS</u>
Annex 8	TREATED LAMINATED-GLASS WINDSCREENS
Annex 9	SAFETY GLASS PANES FACED WITH PLASTICS MATERIAL
Annex 10	GLASS PLASTICS WINDSCREENS
Annex 11	GLASS WINDSCREENS
Annex 12	GLASS WINDSCREENS
Annex 13	GLASS WINDSCREENS
Annex 14	GLASS WINDSCREENS
Annex 15	FLEXIBLE PLASTIC GLAZINGS OTHER THAN WINDSCREENS
Annex 16	RIGID PLASTIC DOUBLE GLAZED UNITS

Today's discussion focused on these glazing.

These shall be considered to belong to **different types** if they differ in at least one of the principal or secondary characteristics

Overview of the certification procedure

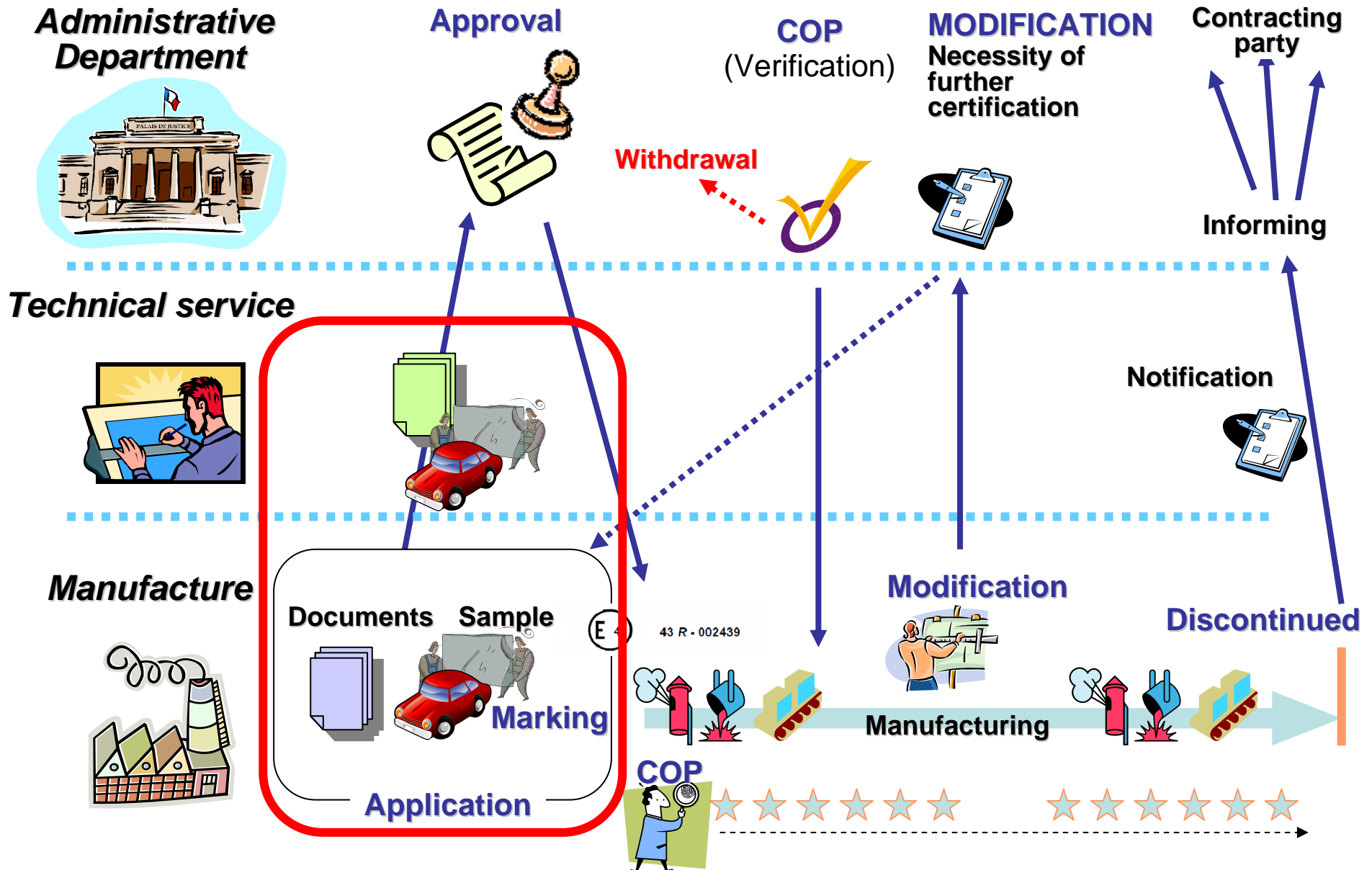

Application for a glazing



The application for approval of a type of glazing shall be submitted by the manufacturer or by his duly accredited representative in the country where the application is made.

Application documents

- A technical description comprising all **principal and secondary characteristics** (Refer to Annex1 and its Appendix 1 to 9)
- **Technical specifications and drawings** required each type of glazing. (Para.3.2.1.1 to 3.2.1.3)

The applicant shall submit a **sufficient number of test pieces and samples** of the finished pieces of the models considered.

E/ECB/324 } Rev.1/Add.42/Rev.2
E/ECB/TRANS/505/ }
Regulation No. 43
page 25
Annex 1 - Appendix 1

Annex 1 - Appendix 1
TOUGHENED-GLASS WINDSCREENS
(Principal and secondary characteristics as defined in annex 4 or annex 9 to Regulation No. 43)

Approval No.: Extension No.:

Principal characteristics:

Shape category:

Thickness category:

Nominal thickness of the windscreen:

Nature and type of plastics coating(s):

Nominal thickness of plastics coating(s):

Secondary characteristics :

Nature of the material (plate, float, sheet glass):

Colouring of glass:

Colouring of plastics coating(s):

Conductors incorporated (yes/no):

Opaque obscuration incorporated (yes/no):

Remarks

Applicants shall submit application documents consists of technical description, specification and drawings and samples.

Application for a vehicle



The application for approval of a vehicle type with regard to the installation of its safety glazing shall be submitted by the vehicle manufacturer or by his duly accredited representative.

Application documents

- Drawings of the vehicle
 - The position of the windscreen relative to the R point
 - The inclination angle of the windscreen,
 - The inclination angle of the seat back;
- Technical details concerning the windscreen and all other glazings
 - The materials used,
 - Approval numbers,
 - Any additional markings

A vehicle representative of the vehicle type to be approved shall be submitted to the technical service responsible for conducting the approval tests.

Applicants shall submit application documents consists of drawings of the vehicles and technical details and a vehicle.

Overview of the certification procedure

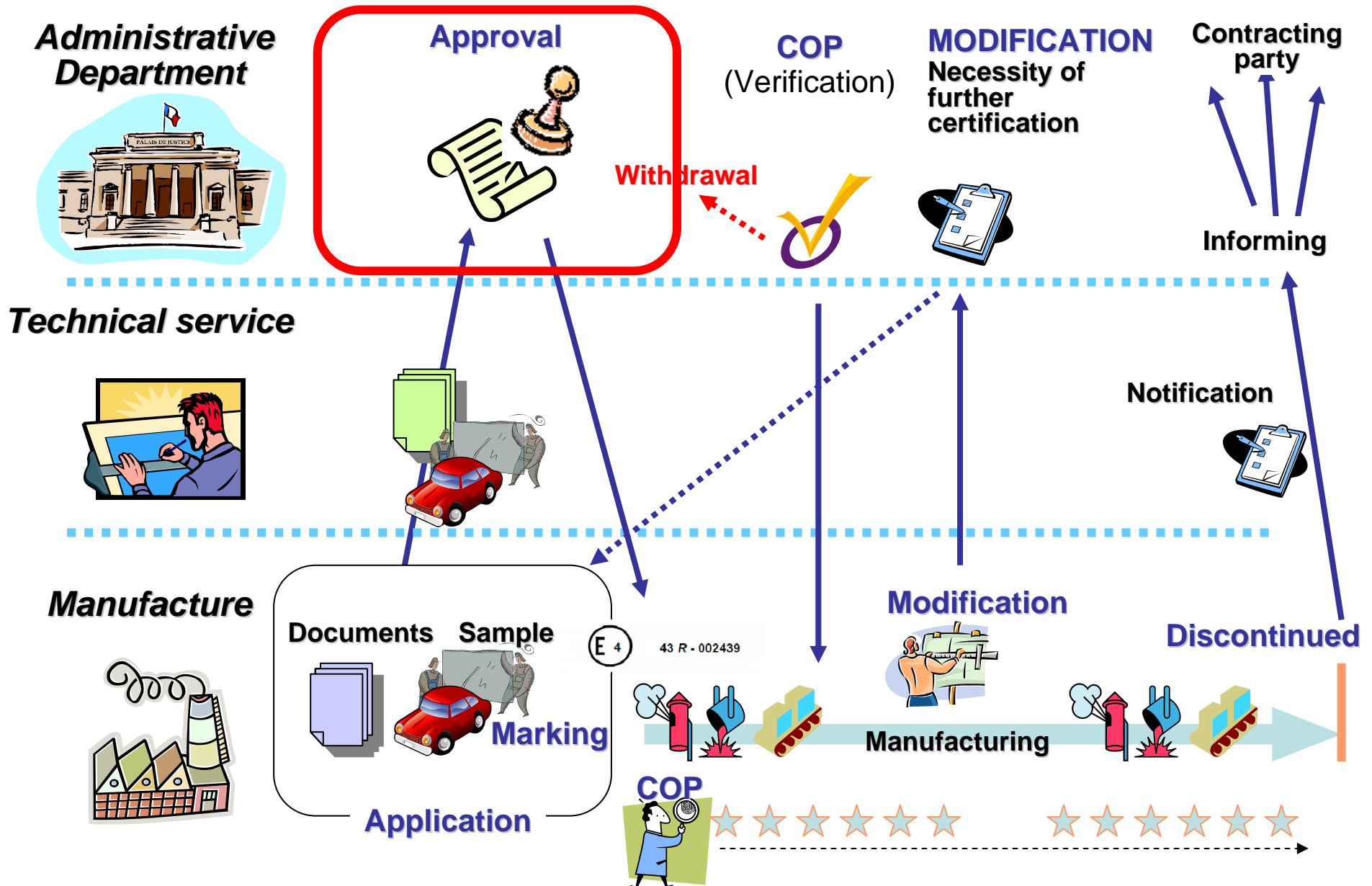

Approval



If the samples submitted for approval meet the requirements of paragraphs 6. to 8. of this Regulation, approval of the pertinent type of safety glazing material shall be granted. An approval number shall be assigned to each type as defined in annexes 5, 7, 11, 12, 14, 15 and 16 or, in the case of windscreens, to each group approved.

Notice of approval or extension of approval or refusal of approval of a type of safety glazing material pursuant to this Regulation shall be communicated to the Parties to the Agreement applying this Regulation

E/CE/324 } Rev.1/Add.42/Rev.2
E/CE/TRANS/505 }
Regulation No. 43
page 23
Annex 1

Annex 1
COMMUNICATION
(Maximum format: A4 (210 x 297 mm))

issued by: Name of administration:
.....
.....

 concerning: 2/ APPROVAL GRANTED
APPROVAL EXTENDED
APPROVAL REFUSED
APPROVAL WITHDRAWN
PRODUCTION DEFINITELY DISCONTINUED

of a type of safety glazing material pursuant to Regulation No. 43.

Approval No. Extension No.

1. Class of safety glazing material:
2. Description of the type of glazing: please refer to appendices 1, 2, 3, 4, 5, 6, 7, 8, and 9 2/, and in the case of windscreens, the list conforming to appendix 10.
3. Trade names or marks:
4. Manufacturer's name and address:
5. If applicable, name and address of manufacturer's representative:

E/CE/324 } Rev.1/Add.42/Rev.2
E/CE/TRANS/505 }
Regulation No. 43
page 24
Annex 1

11. Reason(s) for extension of approval:
12. Remarks:
13. Place:
14. Date:
15. Signature:
16. The list of documents filed with the administrative service which has granted approval and available on request is annexed to this communication.
.....

1/ Distinguishing number of the country which has granted/extended/refused/withdrawn approval (see approval provisions in the Regulation).

2/ Strike out what does not apply.

**Approval number is granted to each type of grazing.
Approval shall be notified to contracting party using the communication.**

Overview of the certification procedure

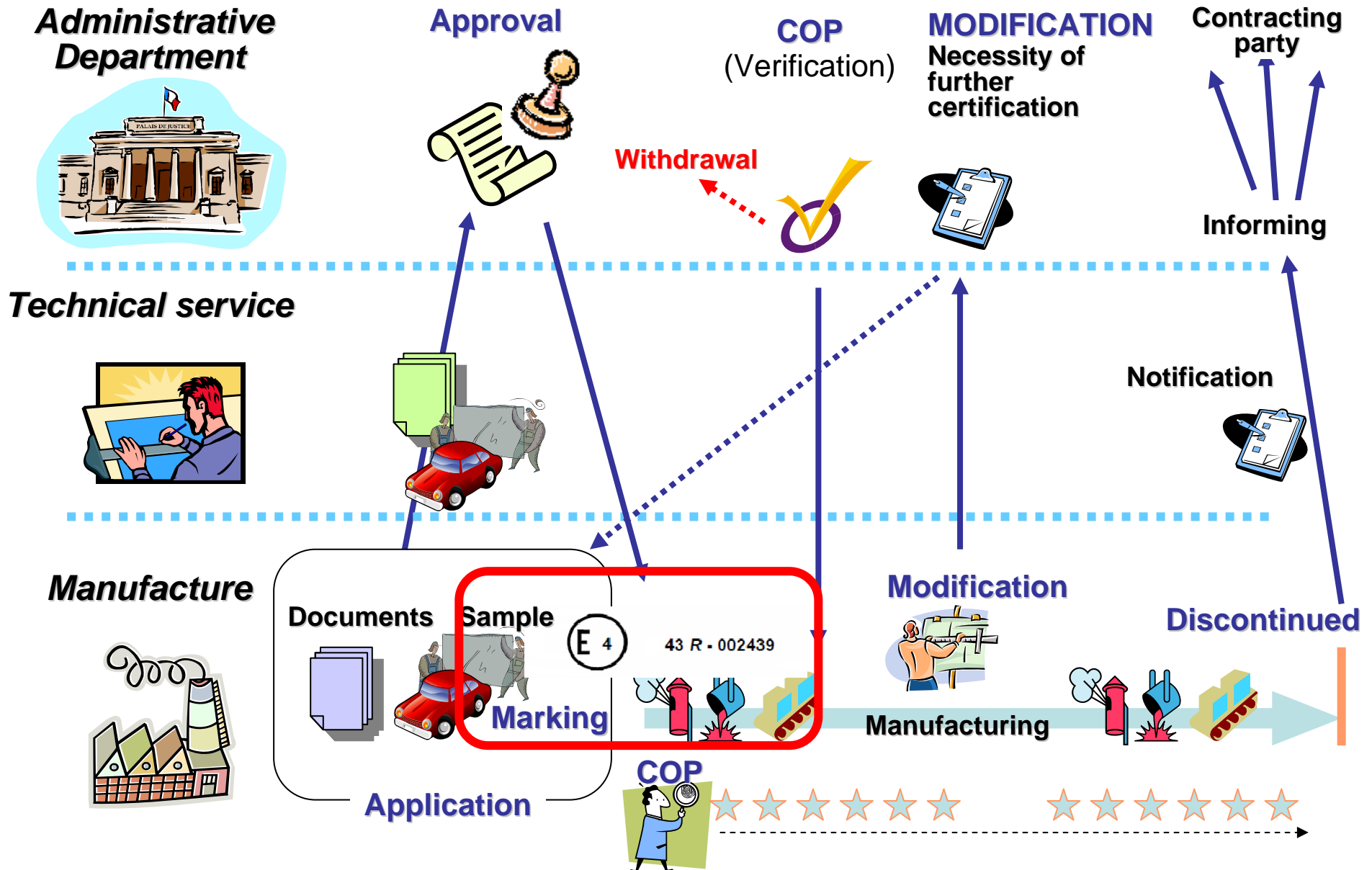

Markings on glazing



There shall be affixed conspicuously to every piece of glazing and double-glazed unit conforming to a type approved under this Regulation, in addition to the marking prescribed in paragraph 4.1., an international approval mark. Any specific approval mark assigned to each pane forming a double-glazed unit may also be affixed.

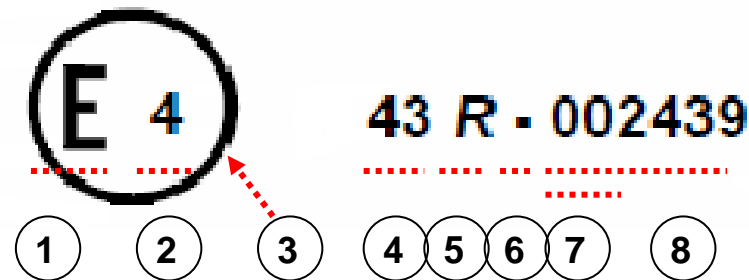

- | | | | |
|---|------------------------|---|-------------------------------|
| ① | “E” | ⑤ | “R” |
| ② | Country Code Number | ⑥ | “-” |
| ③ | Circle surrounding “E” | ⑦ | Series of the regulation “00” |
| ④ | Regulation number | ⑧ | Approval number |

Markings on glazing



For the wind screen, the additional symbols shall be affixed near the above approval mark

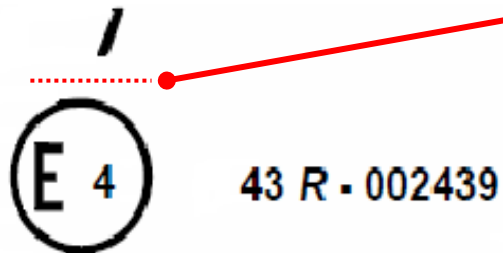

The additional symbols can be combined.

VIII /A/L



<i>I</i>	Toughened glass windscreens
<i>I/P</i>	Toughened glass faced with plastic material
<i>II</i>	Ordinary laminated glass windscreen
<i>II/P</i>	Ordinary laminated glass faced with plastic material
<i>III</i>	Treated laminated glass windscreen
<i>IV</i>	Glass-plastics windscreen
<i>V</i>	Glass panes other than windscreens having a regular light transmittance < 70 per cent
<i>VI</i>	Double-glazed units
<i>VII</i>	Uniformly-toughened glass panes which can be used as windscreens for slow-moving vehicles
<i>VIII</i>	Rigid plastic glazing other than windscreens Symbol /A to /M depend on purpose of use and light scatter characteristics
<i>IX</i>	Flexible-plastic glazing other than windscreens
<i>X</i>	Rigid plastic double-glazed units Symbol /A to /M depend on purpose of use and light scatter characteristics
<i>XI</i>	Laminated glass pane other than windscreen

Markings on vehicles



For the approved glazing ; There shall be affixed conspicuously to every piece of glazing.

For the approved vehicle ; The approval mark shall be clearly legible, be indelible, be placed close to or on the vehicle data plate affixed by the manufacturer.

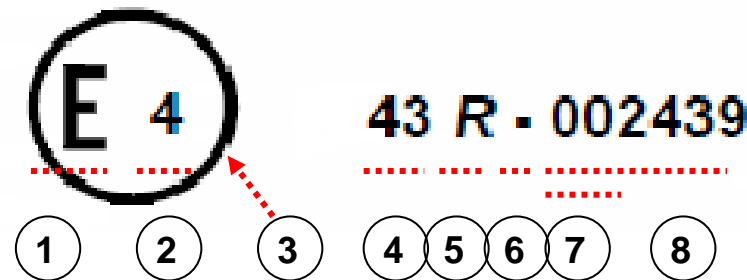

- | | | | |
|---|------------------------|---|-------------------------------|
| ① | “E” | ⑤ | “R” |
| ② | Country Code Number | ⑥ | “-” |
| ③ | Circle surrounding “E” | ⑦ | Series of the regulation “00” |
| ④ | Regulation number | ⑧ | Approval number |

Overview of the certification procedure

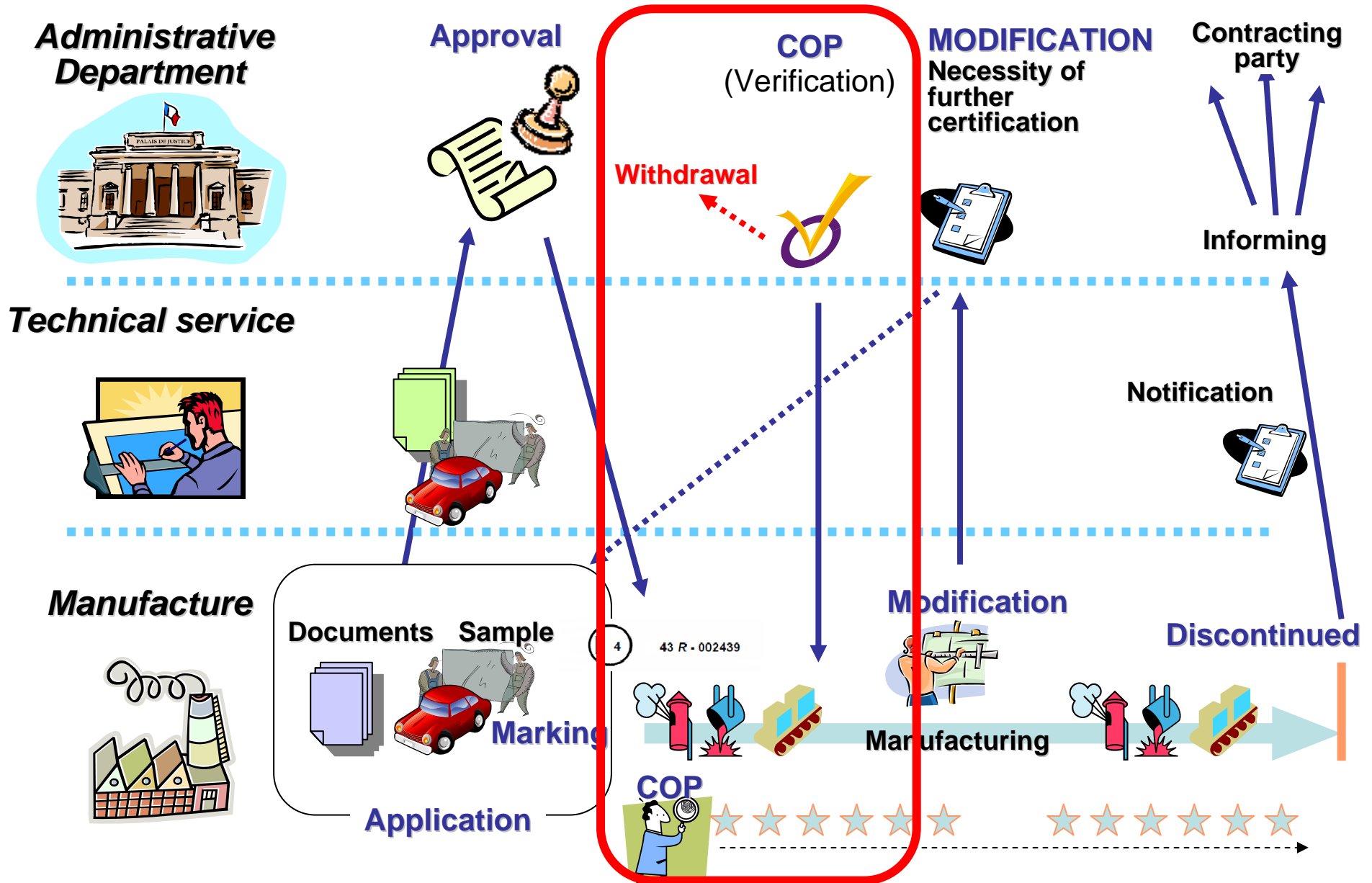

Conformity of production



The conformity of production procedures shall comply with those set out in the Agreement, [appendix 2](#) (E/ECE/324-E/ECE/TRANS/505/Rev.2), with the following requirements:

The checks shall include compliance with the requirements of [annex 20](#) to this Regulation.

**COP procedures for the administrative authority and the manufacture (the approval holders) are provided in Appendix 2 of the 1958 agreement in general and
Details for COP sampling test done by manufacture are provided in annex 20 of R43 in particular.**

The normal frequency of inspection as referred to in paragraph 2.4. of appendix 2 of the Agreement shall be [one per year](#).

PENALTIES FOR NON-CONFORMITY OF PRODUCTION



The approval granted in respect of a type of safety glazing material may be withdrawn if the requirement is not complied with.

If a Party to the Agreement which applies this Regulation withdraws an approval it had previously granted, it shall forthwith so notify the other Contracting Parties applying this Regulation thereof by means of a copy of a communication form conforming to the model in annex 1 to this Regulation.

Approval may be withdrawn if product does not comply with requirements.

Overview of the certification procedure

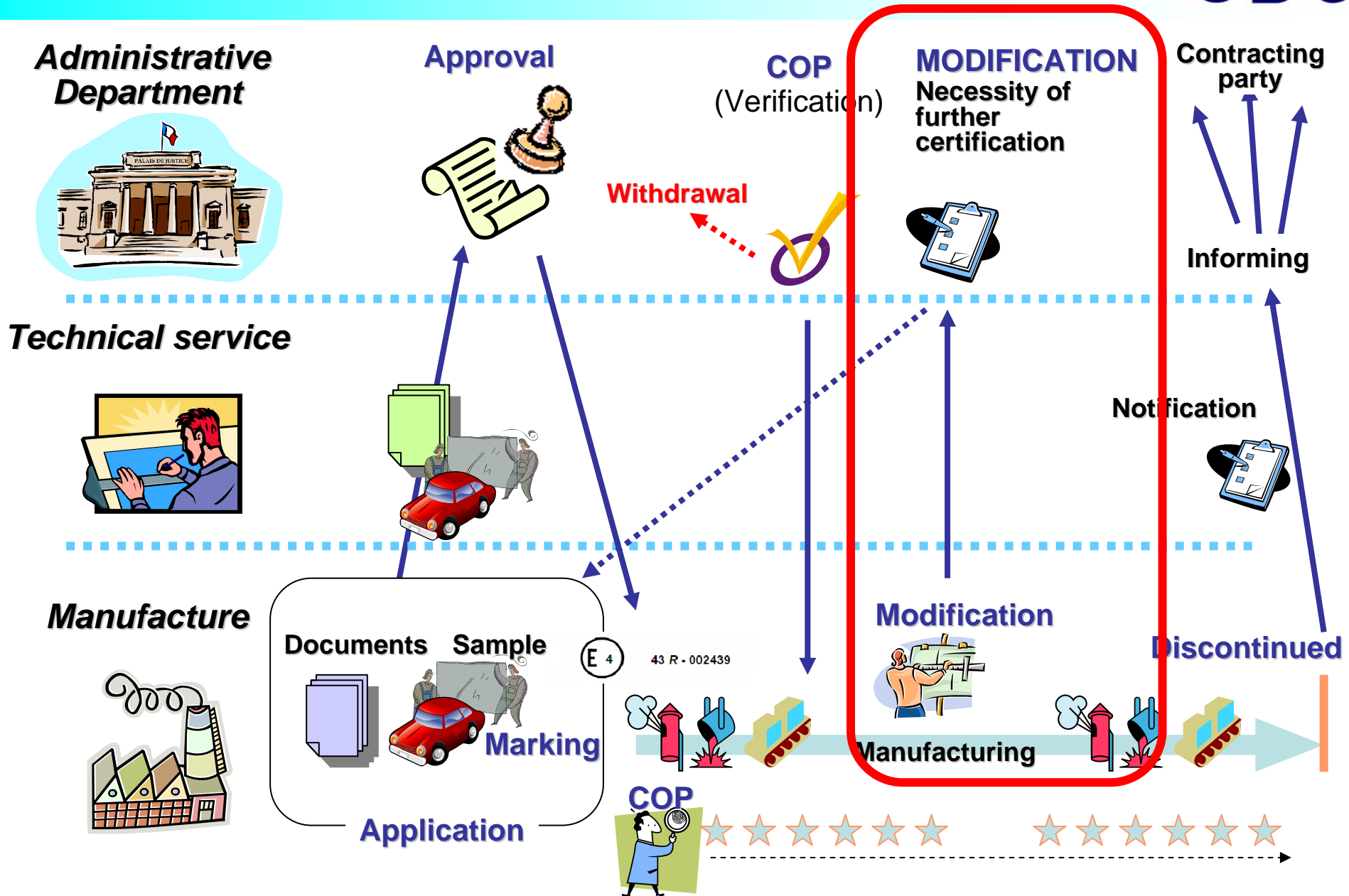

MODIFICATION OR EXTENSION OF APPROVAL



Every modification of a type shall be notified to the administrative department which approved the type of safety glazing material.

Definition of Type is mentioned in annexes of R43 for each specification of glazing.

The department may then either consider that

- the modifications made are unlikely to have an appreciable adverse effect and, in the case of windscreens, that the new type comes within the approved group of windscreens, and that in any case the safety glazing material still complies with the requirements

Approval may cover modification without additional certification.

- require a further test report from the technical service responsible for conducting the tests.

Certification tests are require for extension of approvals.

Overview of the certification procedure

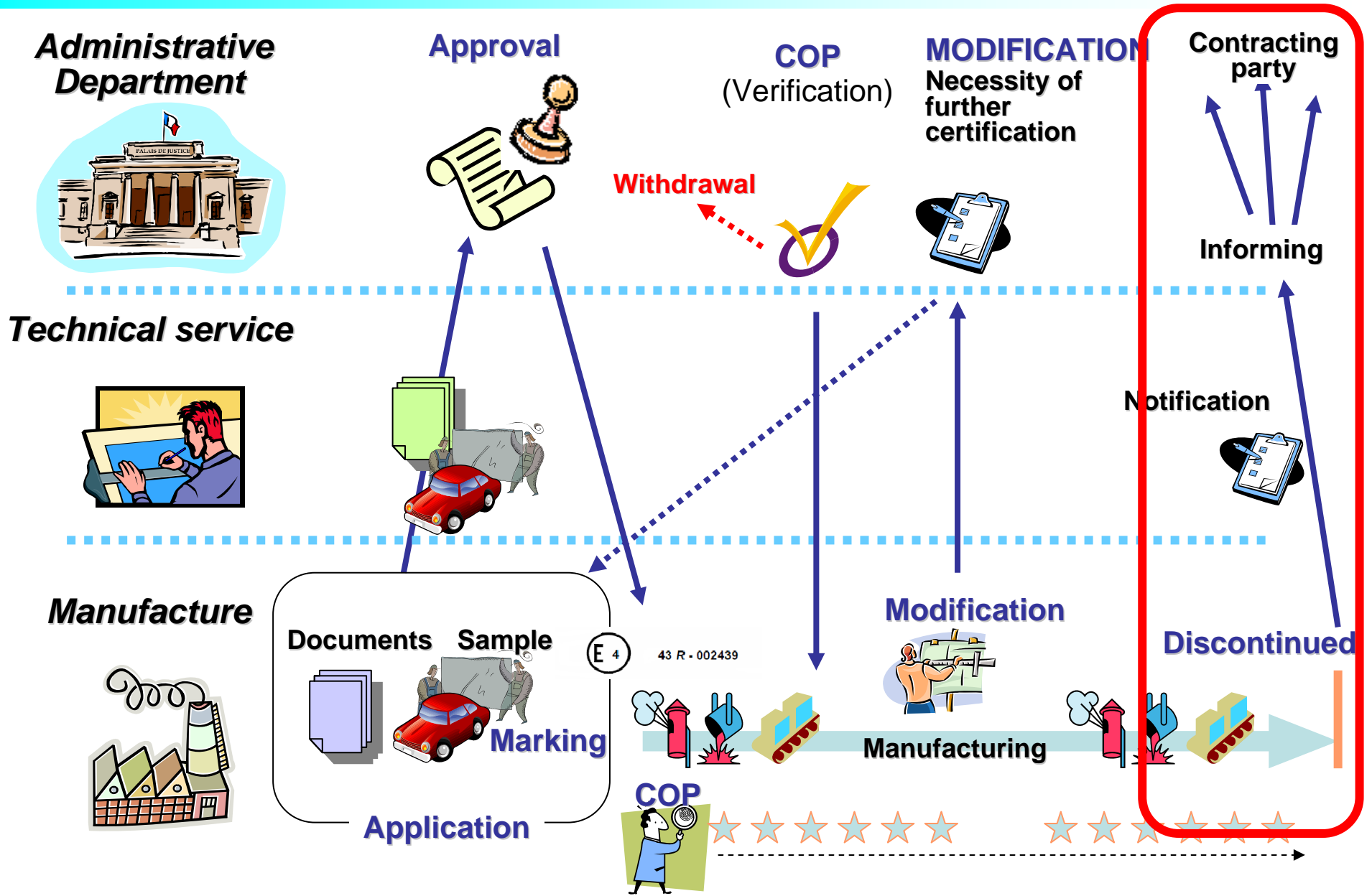

PRODUCTION DEFINITELY DISCONTINUED



If the holder of the approval completely ceases to manufacture a type of safety glazing material approved in accordance with this Regulation, he shall so inform the authority which granted the approval.

Upon receiving the relevant communication, that authority shall inform thereof the other Parties to the Agreement which apply this Regulation by means of a copy of a communication form conforming to the model in annex 1 to this Regulation.

It shall be notified to the administrative authority granted approval if manufacture completely ceases manufacturing approved glazing.

The administrative authority shall inform other contracting party using the communication.

TRANSITIONAL PROVISIONS



- As from the date of entry into force of Supplement 8 to this Regulation in its original form, **no Contracting Party applying this Regulation shall refuse** an application for approval under this Regulation as amended by Supplement 8 to the Regulation in its original form.

- As from 24 months after the official date of the entry into force of Supplement 8, the Contracting Parties applying this Regulation may refuse to recognize the approval of safety glazing not bearing the symbols prescribed in paragraph 5.5. of this Regulation

Additional symbols
above “E”



Thank you for your attention.

Overview of the certification procedure

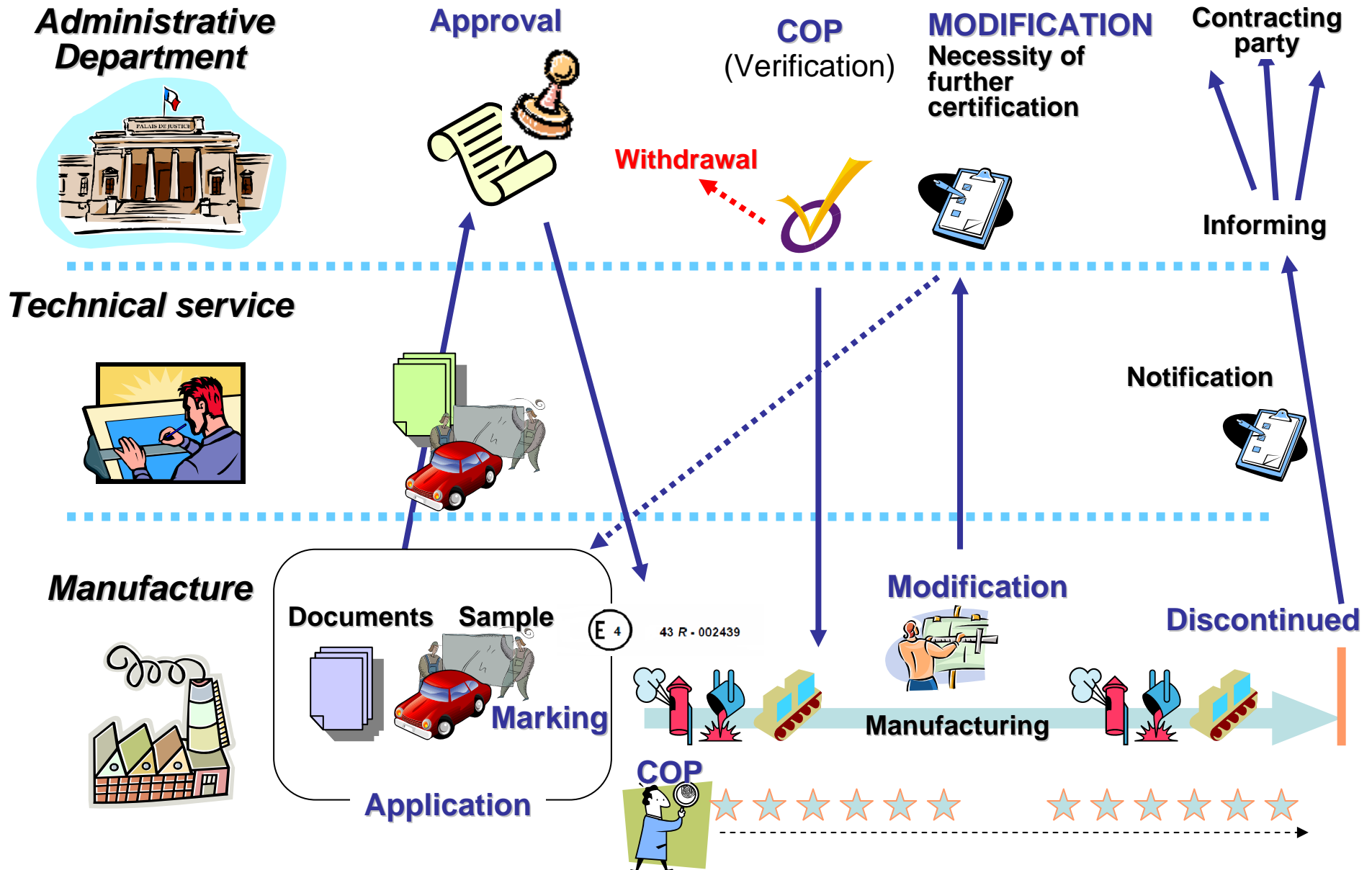



ECE R43 Safety Glazing

Asia Expert Meeting

Masaru Morikawa
JASIC

R43

PURPOSE

The glazing should have a safe performance during the vehicle in use

R43

SCOPE

Safety glazing materials:

Category L, M, N, O, T

Installation:

Category M, N, O

Exclusion of ;

- Glazing for lighting
- Instrument panels
- Bullet-proof glazing
- Light-signalling devices
- Double windows

R43

Applied category

M: Motor vehicles with at least four wheels designed and constructed for the carriage of passengers



R43

Applied category

N: Motor vehicles with at least four wheels designed and constructed for the carriage of goods



R43

Applied category

L: Motor vehicles with less than four wheels

O: Trailers

T: Agricultural and forestry tractors

R43

REQUIREMENTS

1. General requirements
2. Installation on vehicles
3. Safety glazing performance

R43

1. GENERAL REQUIREMENTS

1. Reduce the danger of body injury in the event of shattering
2. Sufficiently resistant in normal traffic, temperature, chemical, abrasion
3. Sufficiently transparent

R43

3. INSTALLATION ON VEHICLES

Purpose

Ensure the driver with a high degree of visibility in all traffic conditions

R43

3. INSTALLATION ON VEHICLES

WINDSCREENS

The light transmittance :
not less than 70%

※ Amendments (75%→70%) has been
approved by WP29 (2008.Nov.)

Reduced test area B for windscreen (2)



R43

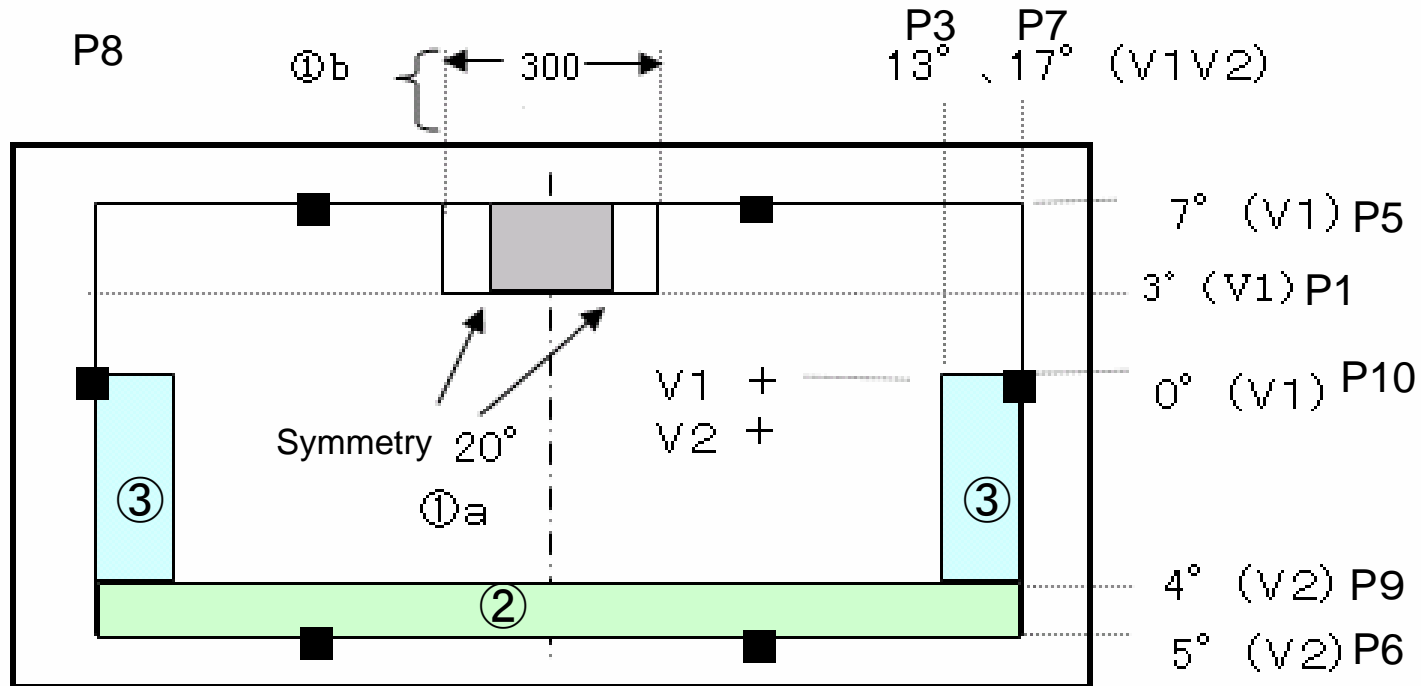

Reduced test area B



: ①a or ①b



: ②



: ③



: Datum points (6points)

R43



R43



R43

3. INSTALLATION ON VEHICLES

Safety glazing other than windscreen

1. Driver's forwards field of vision
 - At least 70%
2. Requisite for the driver's rearward vision
 - At least 70%, but where two exterior rear view mirrors are fitted, allowed below 70%

ECE R43

Technical Requirement
and Testing Method for Glass

Asia Expert Meeting

Masaru Morikawa

JASIC

Type of glass for Automotive (Laminated Glass and Toughened Glass)



(M, N category)

Laminated glass is used for **Windscreen**

Laminated glass or Toughened glass are used for **Glass panes other than windscreens**



Type of glass in R-43

<i>Windscreen</i>	Glass panes other than windscreens
:Laminated glass	:Toughened glass
: Toughened glass	: Laminated glass
:Treated laminated glass	:Glass plastics
:Glass plastics	

Float glass production line flow



Float glass production line flow

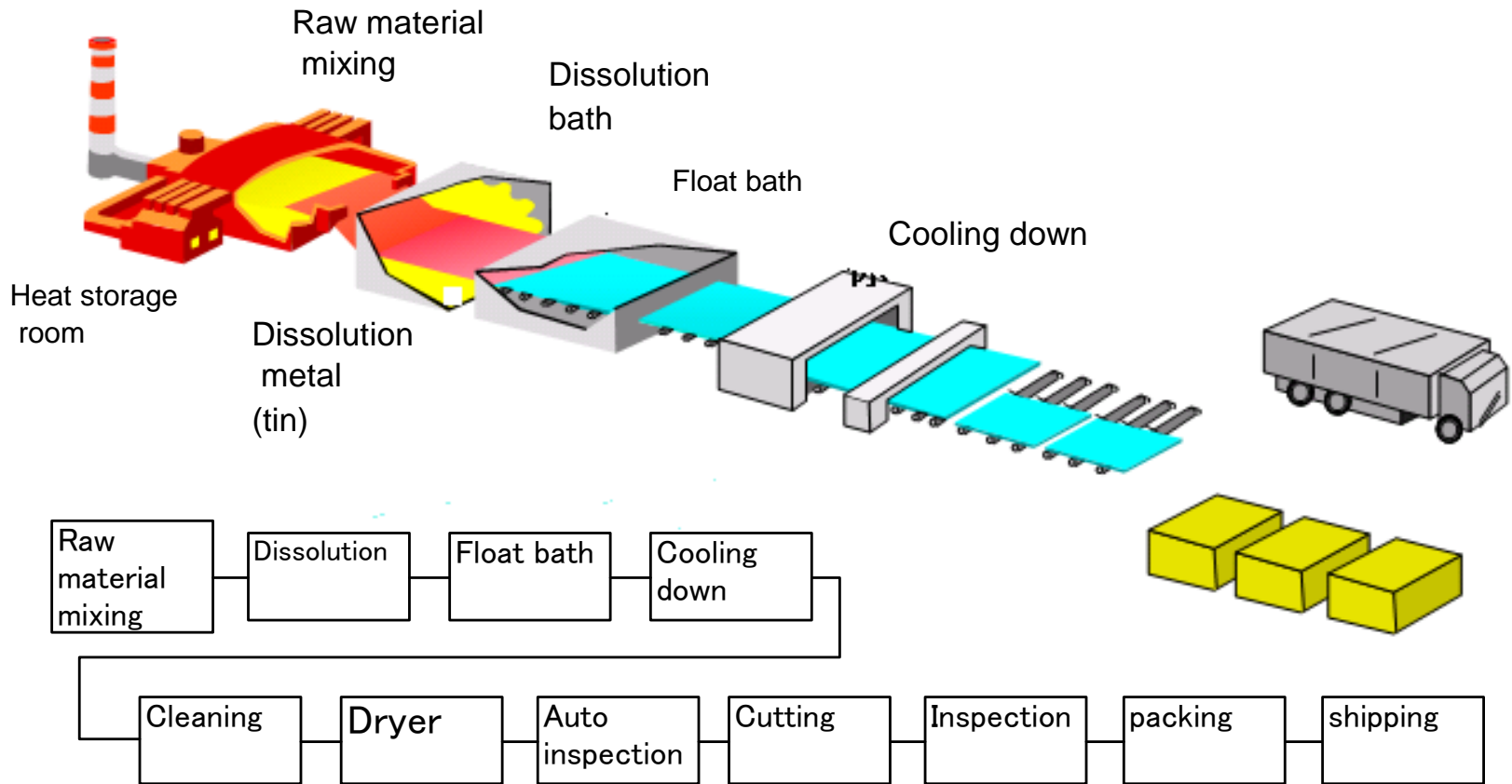

Laminated Glass process

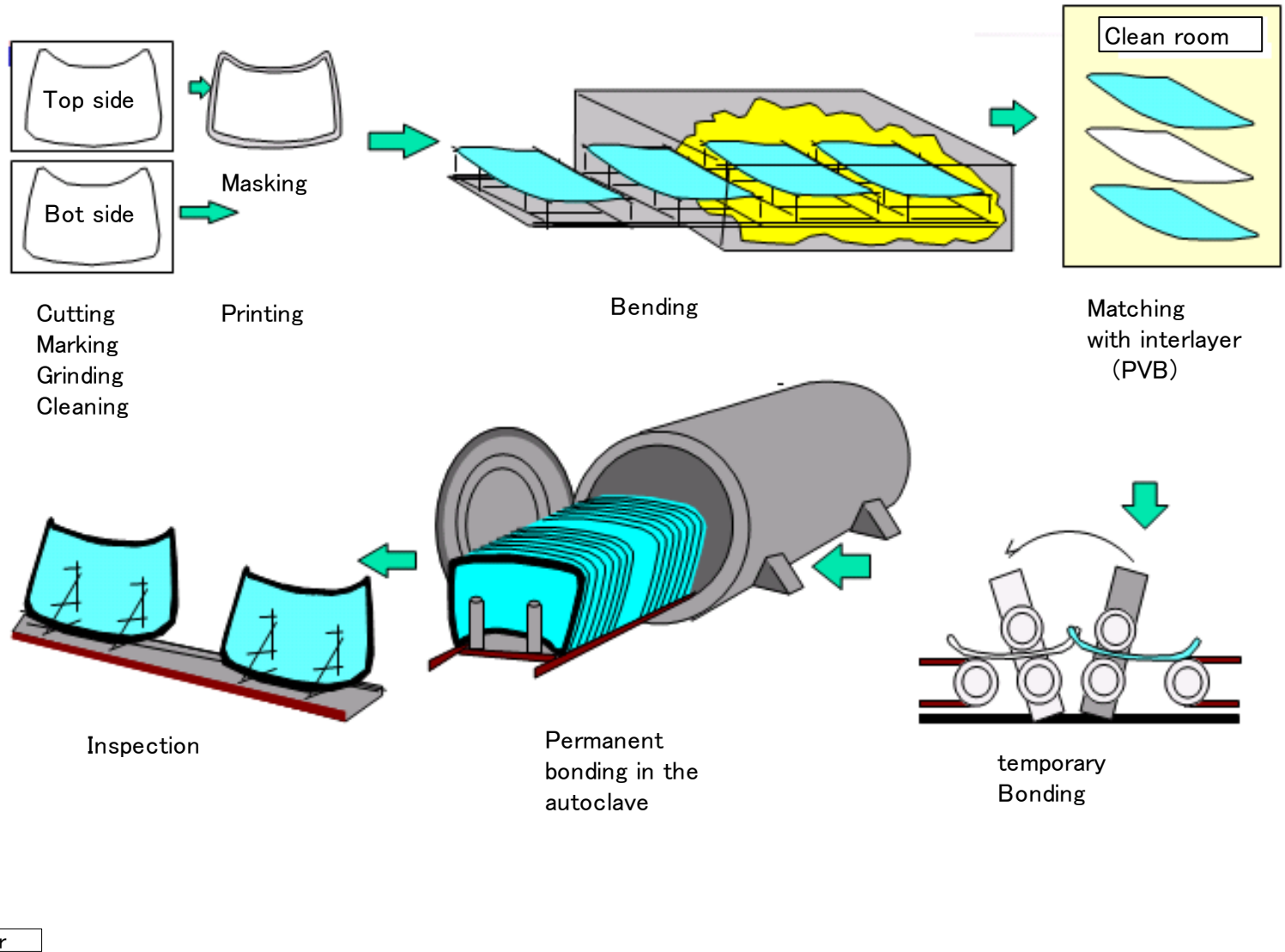

Toughened glass process



In order to realize safety life, Toughened glass is made. The glass manufacturing process are cutting, grinding, cleaning, and furnace. The toughened glass furnace is include bending (heat up), forming, and cooling down process. After heat up the glass, it will be rapid cooling down. The glass surface is harden at first, and glass inside will be cooling down gradually. So we can make the compression strength on glass surface. Its hardness is 3-5 times.

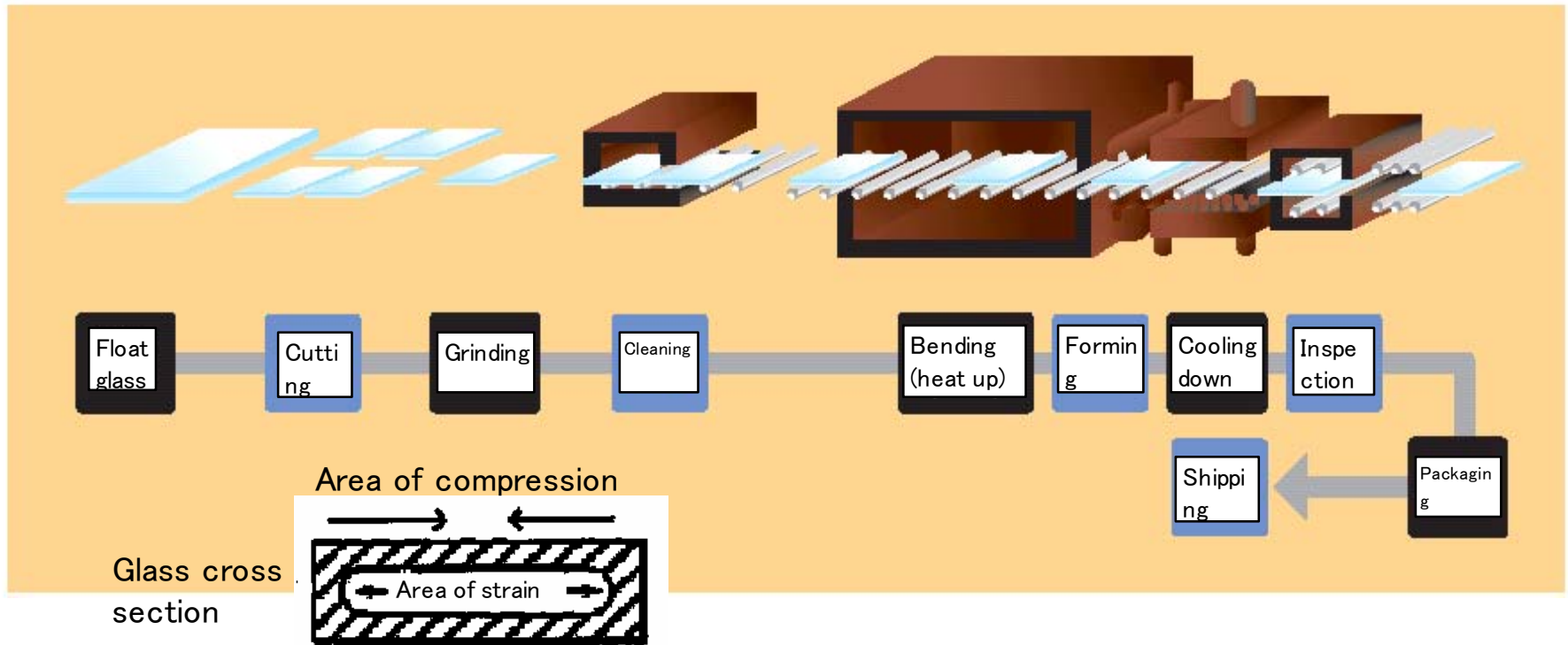

List of Test requirements in ECE R43



Test items		Windscreen	Glass panes other than windscreens	
		Laminated glass	Toughened glass	Laminated glass
(A) Mechanical strength test	(1) Fragmentation test	-	Yes	-
	(2) 227 g ball impact	Yes	Yes	Yes
	(3) 2,260 g ball impact	Yes	-	-
	(4) Head form	Yes	-	Yes
(B) Resistance to the environment	(5) Abrasion	Yes	-	Yes
	(6) High temperature	Yes	-	Yes
	(7) Radiation	Yes	-	Yes
	(8) Humidity	Yes	-	Yes
(C) Optical test	(9) Light transmission	Yes	Yes	Yes
	(10) Optical distortion	Yes	-	-
	(11) Secondary image	Yes	-	-
	(12) Identification of colors	Yes	-	-

(A) Mechanical strength Test

(1) Fragmentation Test

(2) 227g ball impact Test

(3) 2260g ball impact Test

(4) Head Form Test

(1) Fragmentation

Test purpose

Toughened glass is using a heat tempering that increases the mechanical strength, so it resists breakage.

To determine whether the glazing is less likely to cause injury if it does fracture. In the case of breakage, it is desired that the glazing will shatter into very small, blunt pieces rather than large, sharp fragments, thereby significantly reducing the risk of serious injuries.



Raw glass (not toughened)



Toughened glass fragment

Assessment criteria

A, Number of fragments in 50x50mm□

$$40 \leq N_f \leq 400$$

$$40 \leq N_f \leq 450 \text{ (below 3.5t)}$$

B, Largest fragment $\leq 3 \text{ cm}^2$

C, Longest fragment $\leq 75 \text{ mm}$

D, Fragment ends are not knife-edged

E, if fragment extend to the edge of the glass pane, Fragment do not form an angle of more than 45°

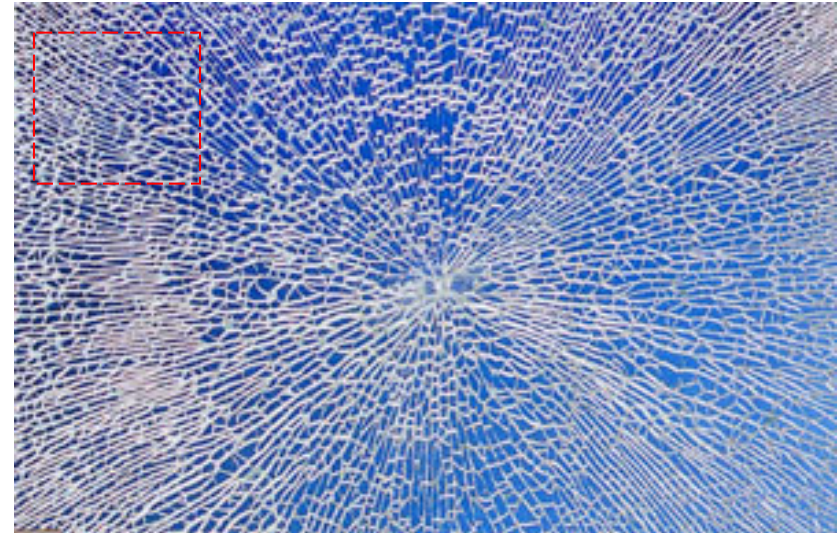

Fragmentation pattern of Toughened glass

(2)-A. Mechanical strength; Ball-impact (227g) for Toughened glass

Test purpose

To assess the resistance of the glazing to impact from stones or other flying objects that might be encountered in everyday use.

Assessment criteria

A, Toughened glass

- Test piece at 20 +/-5 degree C.
- Test piece dose not break (N=6)
- > 3.5mm thickness; 2.5m ball height
- ≤ 3.5mm thickness; 2.0m ball height

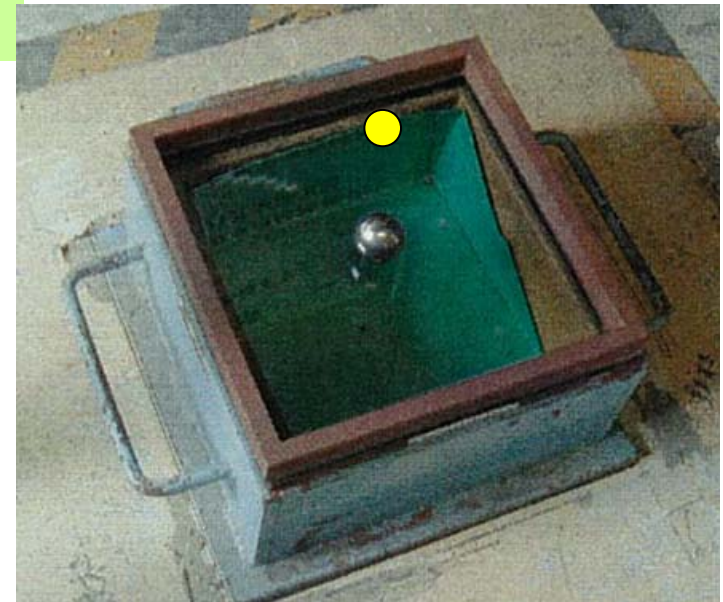

Test equipment

(2)-B. Mechanical strength; Ball-impact (227g) for Laminated glass

Test purpose

To assess the resistance of the glazing to impact from stones or other flying objects that might be encountered in everyday use.

Assessment criteria

B, Laminated glass

- Test piece at +40 degree C and -20 degree C (N=10 each)
- Test piece dose not penetrate or break into several piece
- Detached fragment shall not exceed the appropriate values.
- Ball height 8.5 ~ 12 m depend on thickness

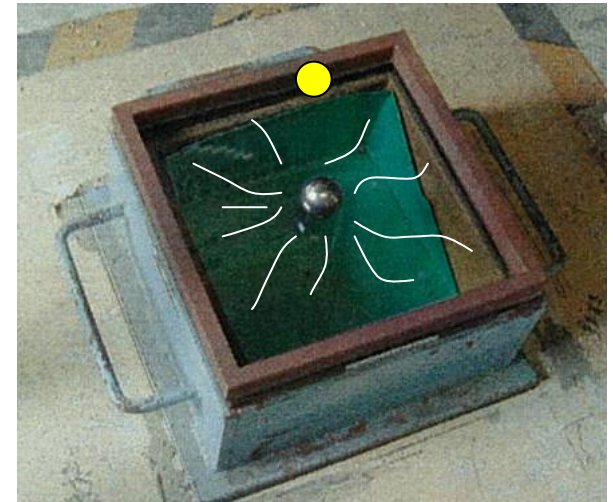

Test equipment

(3) Mechanical strength; Ball-impact (2260g)



Test purpose

To assess the penetration resistance of laminated glazing materials for windscreens to impact from a heavy object.

Assessment criteria

Laminated glass only

- Test piece at at 20 +/-5 degree C (N=6)
- Test piece dose not penetrate in 5 seconds
- Ball height 4.0 m

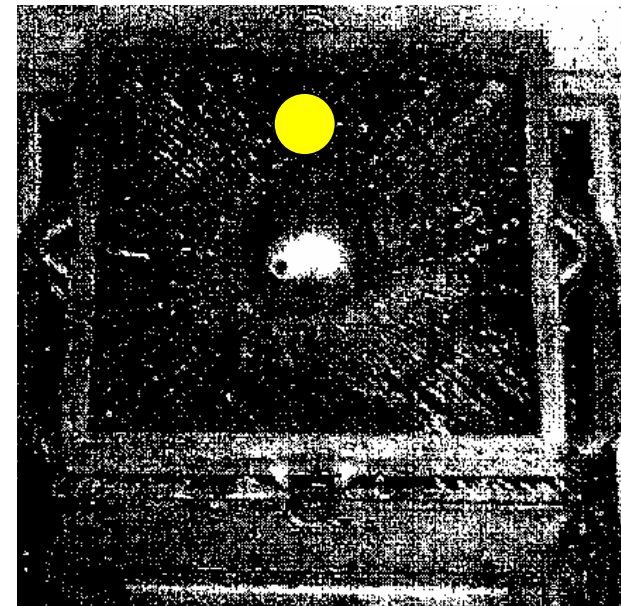

(4) Head-form test

Test purpose

To verify the compliance of glazing with the requirements relating to the limitation of injury in the event of impact of the head against the windscreen.

Assessment criteria

- Laminated glass only
- Test piece at at 20 +/-5 degree C (N=4)
- Laminated windscreen must be broken but not penetrated and must exhibit numerous circumferential and radial cracks.
- Head-form height
1.5 m for windscreen and 4.0 m for flat sample

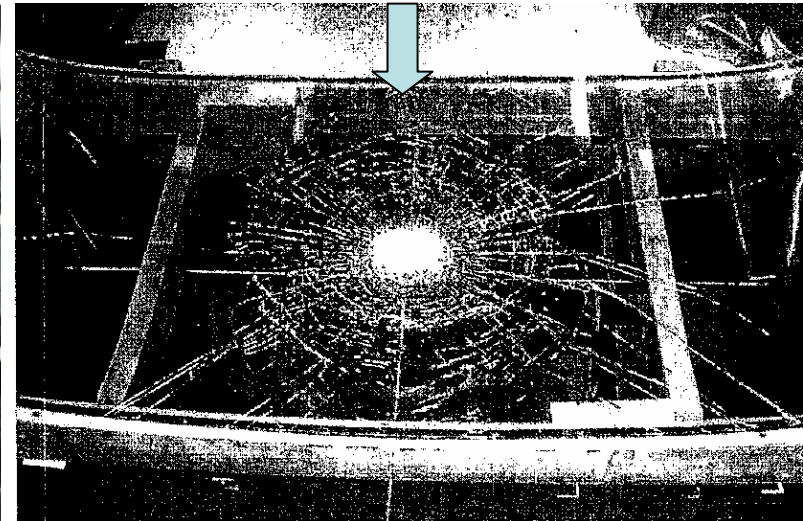
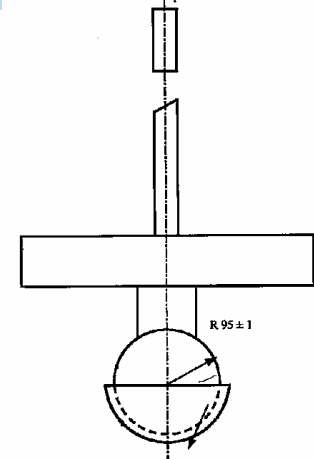

(B) Resistance to the environment Test

(5) Abrasion Test

(6) High temperature Test

(7) Radiation Test

(8) Humidity Test

(5) Resistance to abrasion

Test purpose

To determine whether the safety glazing material will withstand exposure to the environmental conditions normally experienced, without deterioration in appearance and performance.

This test is to determine whether the resistance of a safety glazing to abrasion exceeds a specified value.

Assessment criteria (N=3) 1000rotations

- Abrasive wheel rotate at 65 to 75 rpm with 500g pressure.
- Abrasive wheel shall have a hardness of 72 +/- 5 IRHD.
- Light transmission change shall be less than 2 %.

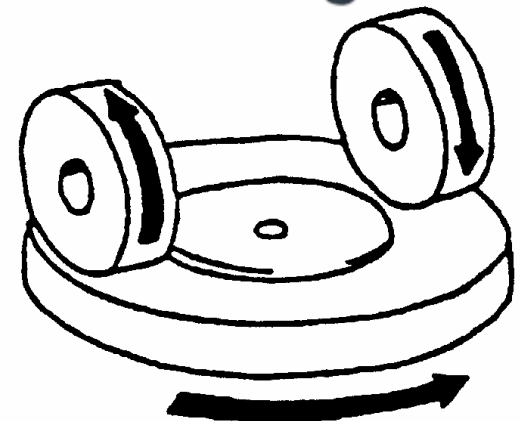

(6) Resistance to high temperature

Test purpose

The purpose of these tests is to determine whether the safety glazing material will withstand exposure to the environmental conditions normally experienced, without deterioration in appearance and performance.

This test is to verify that no bubbles, discoloration or other defects occur in the interlayer in laminated glass when exposed to high temperatures.

Assessment criteria (N=3)

- Heat 100 degree C for a period of 2 hours.
- Glass dose not have bubbles or other defects.



(7) Resistance-to-radiation

Test purpose

The purpose of these tests is to determine whether the safety glazing material will withstand exposure to the environmental conditions normally experienced, without deterioration in appearance and performance.

This test is an accelerated life test using UV light sources.

After exposure to radiation, the test pieces are examined for visual degradation and changes in light transmittance.

Assessment criteria

- UV lamp; 750W (N=3)
- Temperature keep at 45 degree C
- The exposure time shall be 100 hours.
- After exposure to radiation, the test pieces are examined for visual degradation and changes in light transmittance. Light transmittance should be above 95% compare with before, and WS should be above 75%, Other than WS should be above 70% after exposure.

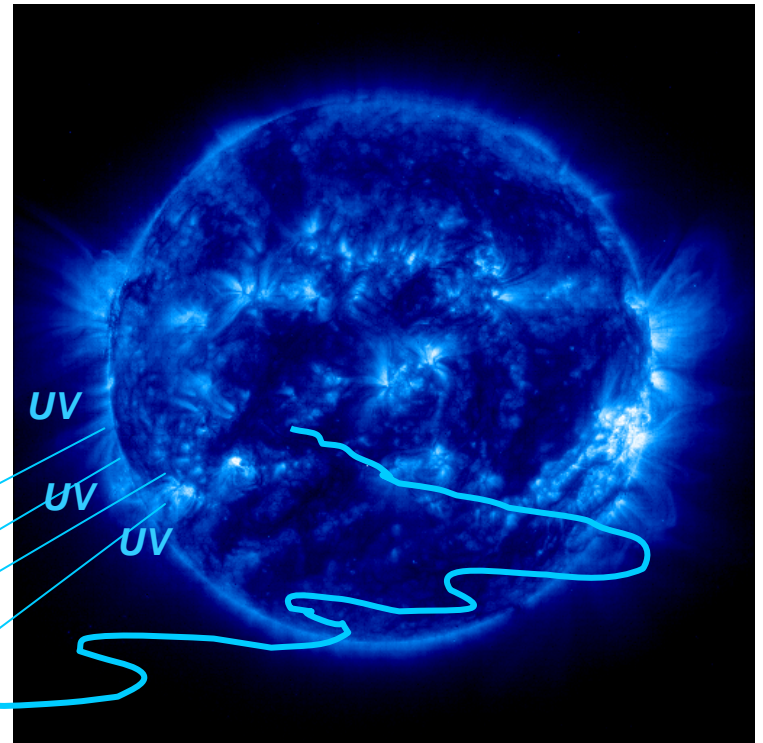

(8) Resistance-to-humidity

Test purpose

The purpose of these tests is to determine whether the safety glazing material will withstand exposure to the environmental conditions normally experienced, without deterioration in appearance and performance.

This test is to verify that no bubbles, discoloration or other defects occur in the interlayer in laminated glass when exposed to high humidity.

Assessment criteria (N=3)

- 50 degree C and 95 %RH, for 2 weeks.
- Glass dose not have significant change , such as bubbles ,discoloration or other defects.



(C) Optical Test

(9) Light transmission Test

(10) Optical distortion Test

(11) Secondary image Test

(12) Identification of colours Test

(9) Light-transmission

Test purpose

This test is to determine whether the regular light transmittance of the safety glazing exceeds a specified value in order to ensure that sufficient visual information is available for safe operation of the vehicle.

Assessment criteria (N=1)

- In the case of windscreen, it shall not be less than 75 %.
- In the case of side window for using forward field of driver's vision, such as Front door window, It shall not be less than 70 %.
- In the case of glazing defined as Safety glazing material requisite for the driver's rearward vision must have a light transmittance of at least 70 %, but where two exterior rear view mirrors are fitted, the glazing is allowed to have a light transmittance below 70 %, provided that it shall bear the symbol V.

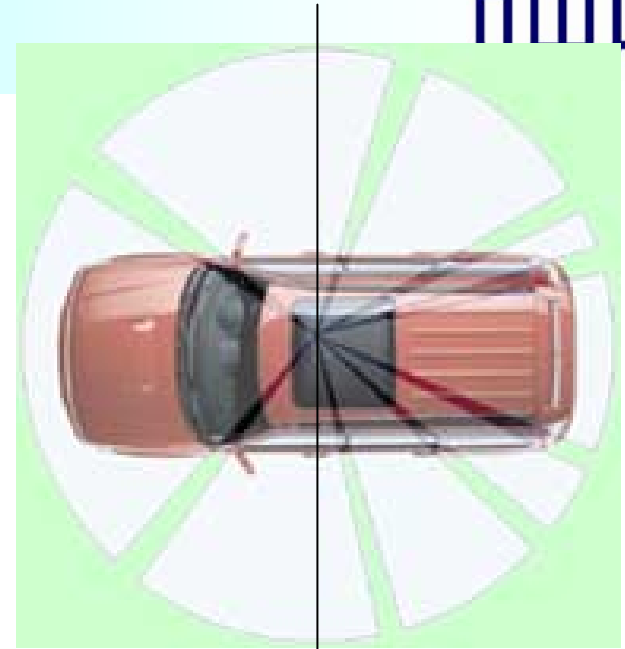

Forward field of driver's vision

Rearward field of driver's vision

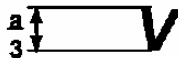

$\frac{a}{3}$ 43 R - 002439

(10) Optical-distortion

(11) Secondary-image-separation

Test purpose

To verify that the distortion of objects as seen through the windscreen is not of such extent as to be likely to confuse the driver.

Limits are specified for distortion and double image.

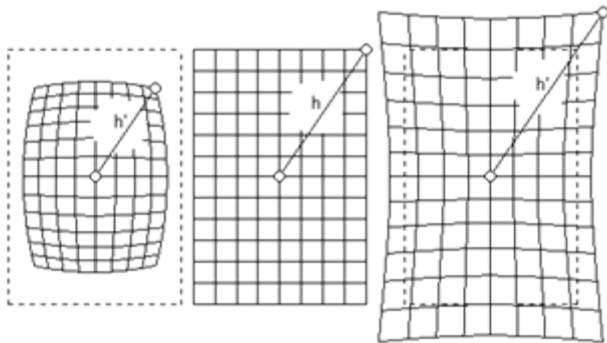

Image of distortion

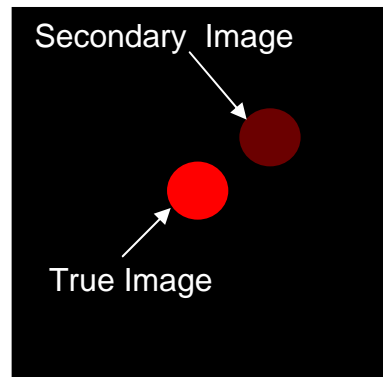
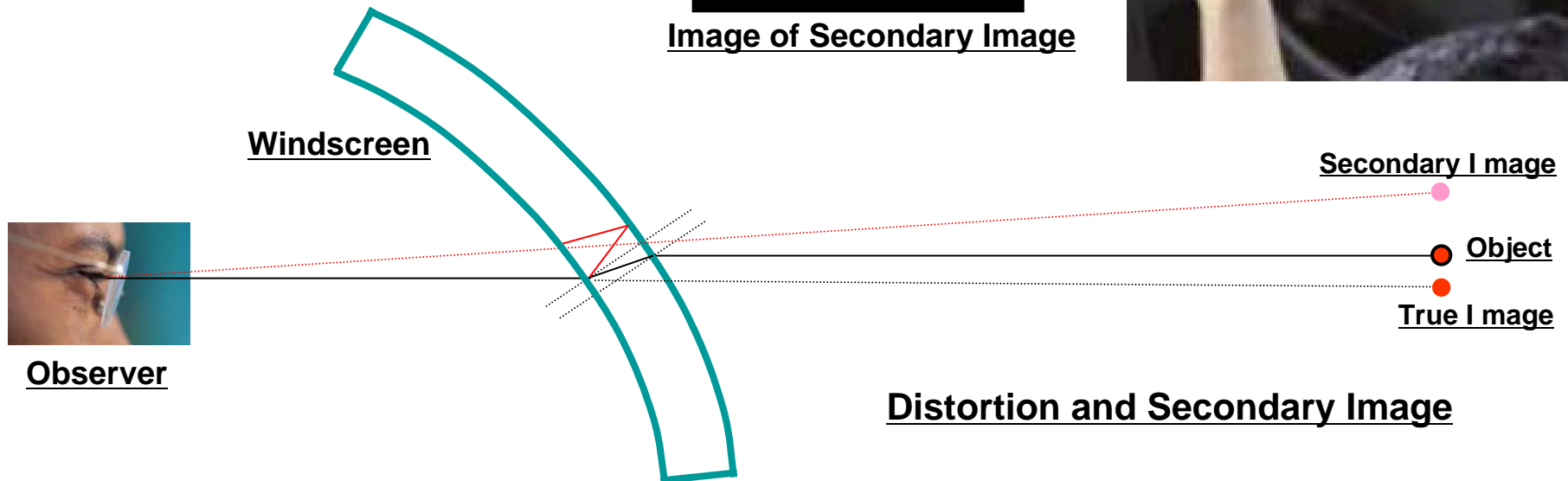

Image of Secondary Image



* Optical-distortion measuring system

Assessment criteria (N=4)

- Optical Zone A and I ; below 2' of arc
- Optical Zone B ; below 6' of arc

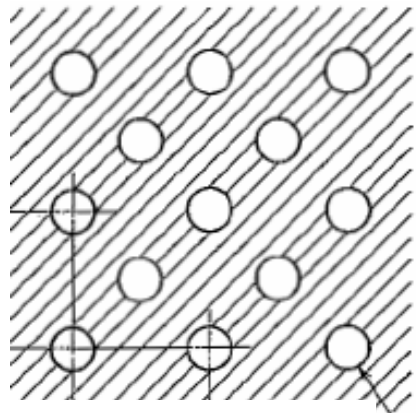

Detail of screen board

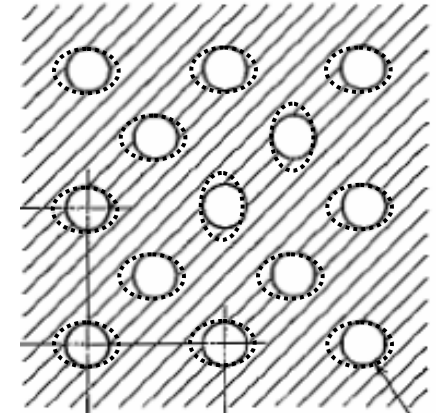
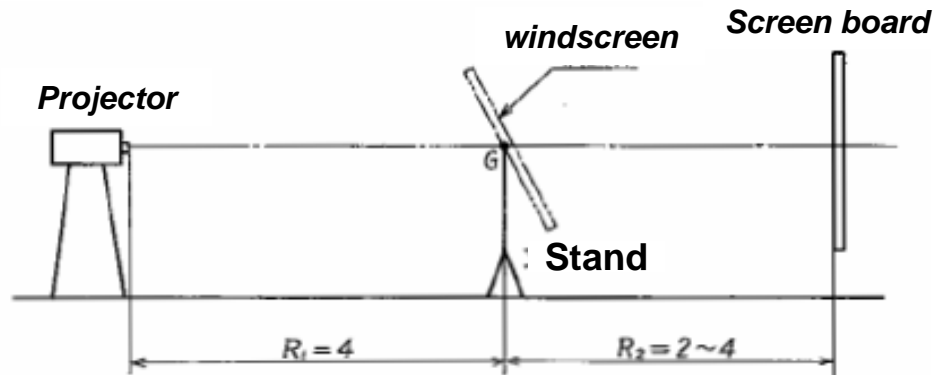

Detail of screen board After through the windscreen

* Secondary-image-separation measuring system

Assessment criteria (N=4)

- Optical Zone A and I ; below 15' of arc
- Optical Zone B ; below 25' of arc

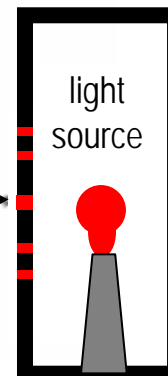
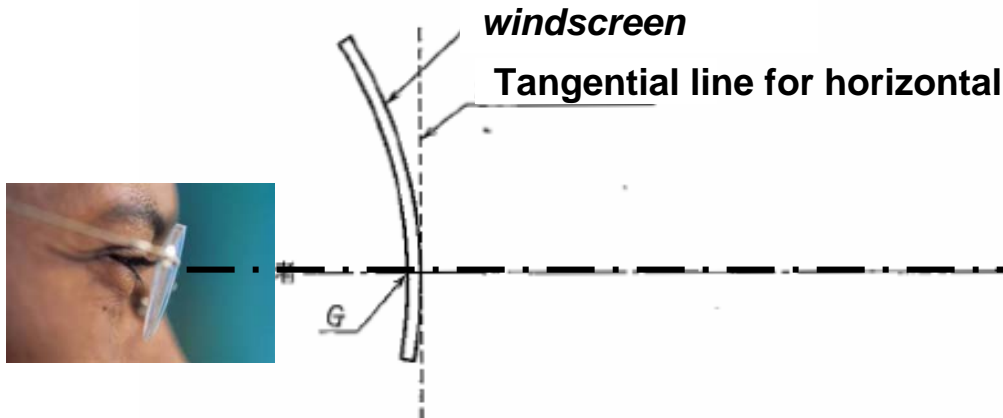

(12) Identification-of-colours

Test purpose

To verify that there is no risk of confusion of colours as seen through a windscreen.

Assessment criteria (N=4)

- Windscreens shall be tested for identification of the following colors: white, selective yellow, red, green, blue, amber..

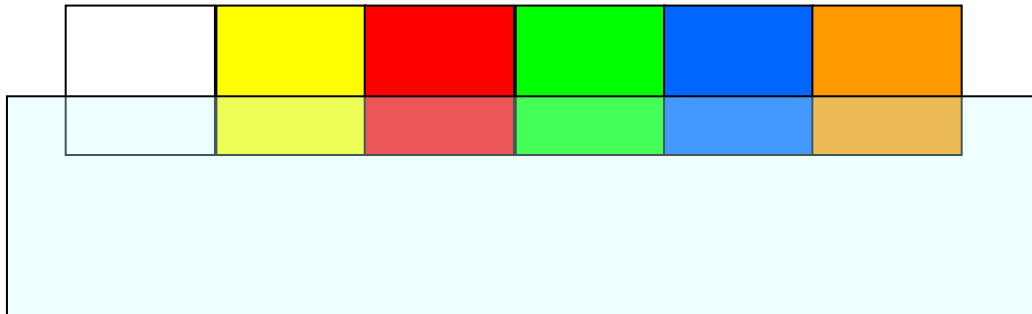

Thank you for your attention



**Japan Automobile Standards
Internationalization Center**

**Contact address :
jasic@jasic.org**

4. Mechanical strength test

4.3.3.2. The height of drop for the various thickness categories and the mass of the detached fragments are given in the table below:

Thickness of test pieces mm	+ 40 degrees C		- 20 degrees C	
	Height of fall m ^{*/}	Maximum permitted mass of the fragments g	Height of fall m ^{*/}	Maximum permitted mass of the fragments g
$e \leq 4.5$	9	12	8.5	12
$4.5 < e \leq 5.5$	10	15	9	15
$5.5 < e \leq 6.5$	11	20	9.5	20
$e > 6.5$	12	25	10	25

^{*/} A tolerance of +25/-0 mm is allowed in height of fall.

Test conditions

Temperature: 20+/-5 degrees C

Pressure: 860 to 1060 mbar

Relative humidity: 60+/-20 percent

Summary Report on the 21st Asia Expert Meeting

Expert Meeting on ECE R41 and R51 (Noise) and ECE R43 (Safety Glazing)

Date: 1 and 2 October 2009

Venue: LTO's Conference Room, Quezon City, Philippines

Attendees

Philippines: About 60 people from government ministries/agencies and industry organizations

JASIC: Mr. Shirahashi, Mr. Yonezawa, Mr. Morikawa, and Mr. Fukuda

Minutes of the Meeting:

Day 1

* About ECE R41 (motorcycles) and R51 (passenger cars)

(by Mr. Shirahashi and Mr. Yonezawa of JASIC's Noise Subcommittee)

First, Mr. Shirahashi presented the general information on the vehicle categories, history of noise regulation, composition of standards, application and approval, COP, etc., which was followed by detailed explanations, including video presentations, by Mr. Yonezawa and Mr. Shirahashi on requirements and test procedures in ECE R41 and ECE R51, respectively. The following questions were raised by attendees. The presentations and Q & A session deepened their understanding of the UNECE Regulations.

(Main questions)

1. Does the certification body in ECE Regulations refer to the government agency or a third-party institution?

A: Under ECE Regulations, a third-party institution conducts certification testing. Based on the test results, the government agency grants approvals.

2. There are durability requirements for mufflers in which glass wool is used, but are there any provisions for mufflers in which asbestos is used? (Motorcycle muffler industry?)

A: Asbestos is banned in most of the advanced countries, and there is no provision that assumes the use of asbestos in ECE Regulations. It is acknowledged that no asbestos is used.

3. How do the emissions regulation (Euro 2, etc.) and noise regulation correspond in their respective versions?

A: The latest version of the noise regulation is R41-03. The timing for switching from Euro 2 to Euro 3 differs from that from R41-02 to R41-03. Euro 3 vehicles all comply with R41-03. For Euro 2 vehicles, some of them comply with R41-02 while others with R41-03.

4. Can you achieve compliance with R51/02 using the Euro 2 system and Euro fuel?

A: To date, the emissions regulation and noise regulation have been upgraded in parallel with each other. If you change the combination, new development will be necessary. We don't have such experience, so we can't answer that question now.

5. There is the provision stating that the engine must be sufficiently warmed-up prior to noise testing, but is there no provision that specifies any absolute value (i.e., degrees of the temperature)?

A: There is no provision that specifies any absolute value. The condition where the coolant temperature, oil temperature, etc. in the engine is stabilized is considered as "being sufficiently warmed-up".

6. Also, in the Philippines, which is the tropical region, at what temperature should we conduct the testing?

A: No absolute value is specified in the regulation. Since the purpose of the testing is to measure stabilized noise data, any condition where no fluctuation in noise data occurs is good. You can use, for example, the coolant temperature gauge on the vehicle for reference.

7. Both R41 and R51 require acceleration noise testing and exhaust proximity noise testing. Which testing is better? (DOTC)

A: Neither is better than the other. You need to choose the method that is more appropriate for the purpose of testing. In vehicle approval testing, the result of acceleration noise testing, based on which the vehicle's overall noise can be evaluated, is used. Acceleration noise testing is mandatory. Proximity noise testing is not required unless data on changes in the exhaust noise are necessary for controlling in-use vehicles, etc. (Data from proximity noise testing are obtained as original vehicle data and considered as reference data for the purpose of controlling noise increase due to deterioration or damage of exhaust pipes of in-use vehicles, replacement mufflers, etc.)

8. Do you have any suggestions to the Philippine government?

A: As regards ECE-R41, we hope that it will be adopted without any change. In addition, we recommend using relative values for exhaust proximity noise in controlling in-use vehicles on roads, etc. and replacement mufflers as well. (The capture effect is higher when relative values are used than when absolute values are used; besides, relative values are more logically explainable.)

9. Do you have any noise regulation for in-use vehicles?

A: Yes, we do. In April 2010, the muffler part certification system will take effect.

10. I'm afraid that this is an elementary question, but why do we need noise regulation? (DOTC)

A: Vehicle noise regulation is necessary for ensuring that people can live in a quiet environment, as road traffic is one of the noise sources and its noise should be reduced. Vehicle acceleration noise is considered to be the basic contributing factor to the road traffic noise. Therefore we are able to reduce environmental noise by measuring acceleration noise and including it in the regulation.

11. How were the noise limits established for ECE Regulations? (DOTC)

A: As the current noise regulations were amended 14 years ago, we do not know exactly how they were established. However, generally speaking, through considering noise regulation that is deemed necessary in terms of environmental noise as well as the currently available noise reduction technologies, technical requirements have been developed at GRB meetings and adopted at WP.29 meetings by the Contracting Parties.

Day 2

* About ECE R43 (Safety Glazing)

(by Mr. Morikawa of JASIC's General Safety Subcommittee)

Mr. Morikawa gave presentations firstly on an overview of procedures for obtaining approvals under UN/ECE R43 (Safety Glazing) (including application for an approval, granting of the approval, application for modification of the approval, and COP), secondly on the applicable categories of safety glass and their installation on vehicles, and finally on the test requirements and procedures, etc. in detail (including manufacturing methods for various types of safety glass). The following questions were raised by attendees. The presentations and Q & A session deepened their understanding of the UNECE Regulation.

(Main questions)

1. About the testing environment, is there any problem with the hot weather in the Philippines?

A: You need to follow the specifications of the environment in the regulation, such as the temperature. You need an environment that you can control for testing.

2. In the strength test, why do you not use an actual vehicle?

A: The current test procedures were determined based on the results of sled tests, etc.

3. How do you consider the attachment of film?

A: Under R43, it is not allowed on the windscreen.

4. There must be many different objects for giving impact. Why do you use balls?

A: It was concluded that balls can represent them.

* * * * *